

This Manual Must Be Read Before Operating The Equipment

# Owner / Operator's Manual



Spreaders for Snow & Ice Control

FOR MODEL

SP-9500



Warren, Michigan 48089  
800-725-8377

CUSTOMER COPY

Protected by the following patents, #6,089,478, #6,088,865, #Des.425,915  
and other pending U.S. and foreign patent applications.

Introduction .....	3
General Information and Registration .....	4
Safety Information .....	5 - 7
Spreader Assembly and Exploded Views.....	8 - 17
Wiring Instructions .....	18
Electrical System Information.....	19 - 22
Spreader Mounting System.....	23 - 25
Spreader Operating Information .....	26 - 30
Troubleshooting Information .....	31 - 32
Spreader Maintenance .....	33
Determine Vehicle Payload Chart .....	34
Blank and Note Pages .....	35 - 37
Warranty .....	38 - 39

Have a question or need assistance?  
**SnowEx Customer Service**  
**(800) 725-8377**

or (586) 756-6555

Monday through Friday 8:00 AM to 4:30 PM EST

Fax: (586) 427-0552

E-Mail: [customercare@trynexusfactory.com](mailto:customercare@trynexusfactory.com)

Website: [www.snowexproducts.com](http://www.snowexproducts.com)

This manual has been designed for your help. It will assist you and instruct you on the proper set-up, installation and use of this spreader. Refer to the table of contents for an outline of this manual.

We require that you read and understand the contents of this manual completely (especially all safety information) before attempting any procedure contained herein.



THIS SIGN SHOULD ALERT YOU:

The Society of Automotive Engineers has adopted this SAFETY ALERT SYMBOL to pinpoint characteristics that, if NOT carefully followed, can create a safety hazard. When you see this symbol in this manual or on the machine itself, BE ALERT! Your personal safety and the safety of others is involved.

Defined below are the SAFETY ALERT messages and how they will appear in this manual:



**DANGER**

(RED)

Information that, if not carefully followed, can cause death!



**WARNING**

(ORANGE)

Information that, if not carefully followed, can cause serious personal injury or death!



**CAUTION**

(YELLOW)

Information that, if not carefully followed, can cause minor injury or damage to equipment.

CONGRATULATIONS!

The spreader you have purchased is an example of snow and ice control technology at its finest! Your spreader's innovative, self-contained design is a trademark of all Trynex products. Here's why...

**SIMPLICITY:** Fewer moving parts manufactured of higher quality means minimal maintenance for your SnowEx spreader.

**RELIABILITY:** High impact linear low density polyethylene hopper, state-of-the-art electronic dual variable speed control, custom engineered powder coated frame, maximum torque 12 volt motor coupled to a custom engineered transmission found only on SnowEx products.

**VERSATILITY:** Multi-use capabilities allows spreading of a variety of materials for snow and ice control.

**WARRANTY:** Best in the industry, hands down! 2 Years Standard and now a 5 Year Extended (optional).

The benefits you are about to recognize are that of time, money and effort.

**We welcome you to the world of Trynex Performance.**

## Registration

Record the following information in this manual for quick reference.

Spreader Model Number \_\_\_\_\_

Spreader Serial Number \_\_\_\_\_ Controller Serial Number \_\_\_\_\_

Date of Purchase \_\_\_\_\_

Dealer Where Purchased \_\_\_\_\_

When ordering parts, the above information is necessary. This will help to insure that you receive the correct parts.

At the right is a diagram of the ID tag. This tag on the spreader is located on the frame.

Please fill out the warranty card with all the necessary information to validate it. This will also give us a record so that any safety or service information may be communicated to you.





Before attempting any procedure in this book, these safety instructions must be read and understood by all workers who have any part in the preparation or use of this equipment.

For your safety warning and information decals have been placed on this product to remind the operator of safety precautions. If anything happens to mark or destroy the decals, please request new ones from Trynex, International.



Unit must be strapped down and locked into position before operating vehicle.



Never exceed the Gross Vehicle Weight Rating of vehicle. Failure to do so may limit a vehicle's handling characteristics.



Never attempt to take a unit off a truck with material in it.



Never exceed 45 m.p.h. when loaded spreader is attached to vehicle. Braking distances may be increased and handling characteristics may be impaired at speeds above 45 m.p.h.



Never allow children to operate or climb on equipment.  
Always check areas to be spread to be sure no hazardous conditions or substances are in the area.  
Always inspect unit for defects: broken, worn or bent parts, weakened areas on spreader or mount.



Always shut off vehicle and power source before attempting to attach or detach or service spreader unit. Be sure vehicle/power source is properly braked or chocked.



Always keep hands, feet, and clothing away from power-driven parts. Remember it is the owner's responsibility to communicate information on safe usage and proper maintenance of all equipment.



Always make sure personnel are clear of areas of danger when using equipment. Maintain 60' distance from all bystanders when operating the spreader.



Inspect the unit periodically for defects. Parts that are broken, missing, or worn out must be replaced immediately. The unit, or any part of it cannot be altered without prior written permission from the manufacturer.



Never use V-Maxx 9500 with foreign debris in the spreader. These units are designed to handle clean, free-flowing material.

 **WARNING**

Always inspect pins and latches whenever attaching or detaching spreader, and before traveling.

 **CAUTION**

Never leave material in hopper for long periods of time. Be aware that all ice melters are hygroscopic and will attract atmospheric moisture and harden up.

 **WARNING**

Remember, most accidents are preventable and caused by human error. Exercising of care and precautions must be observed to prevent the possibility of injury to operator or others!

 **WARNING**

Never operate equipment when under the influence of alcohol, drugs, or medication that might alter your judgment and/or reaction time.

 **WARNING**

Before working with the spreader, secure all loose fitting clothing and unrestrained hair.

 **WARNING**

Always wear safety glasses with side shields when servicing spreader. Failure to do this could result in serious injury to the eyes.

# Safety and Warning Labels

Model # SP-9500

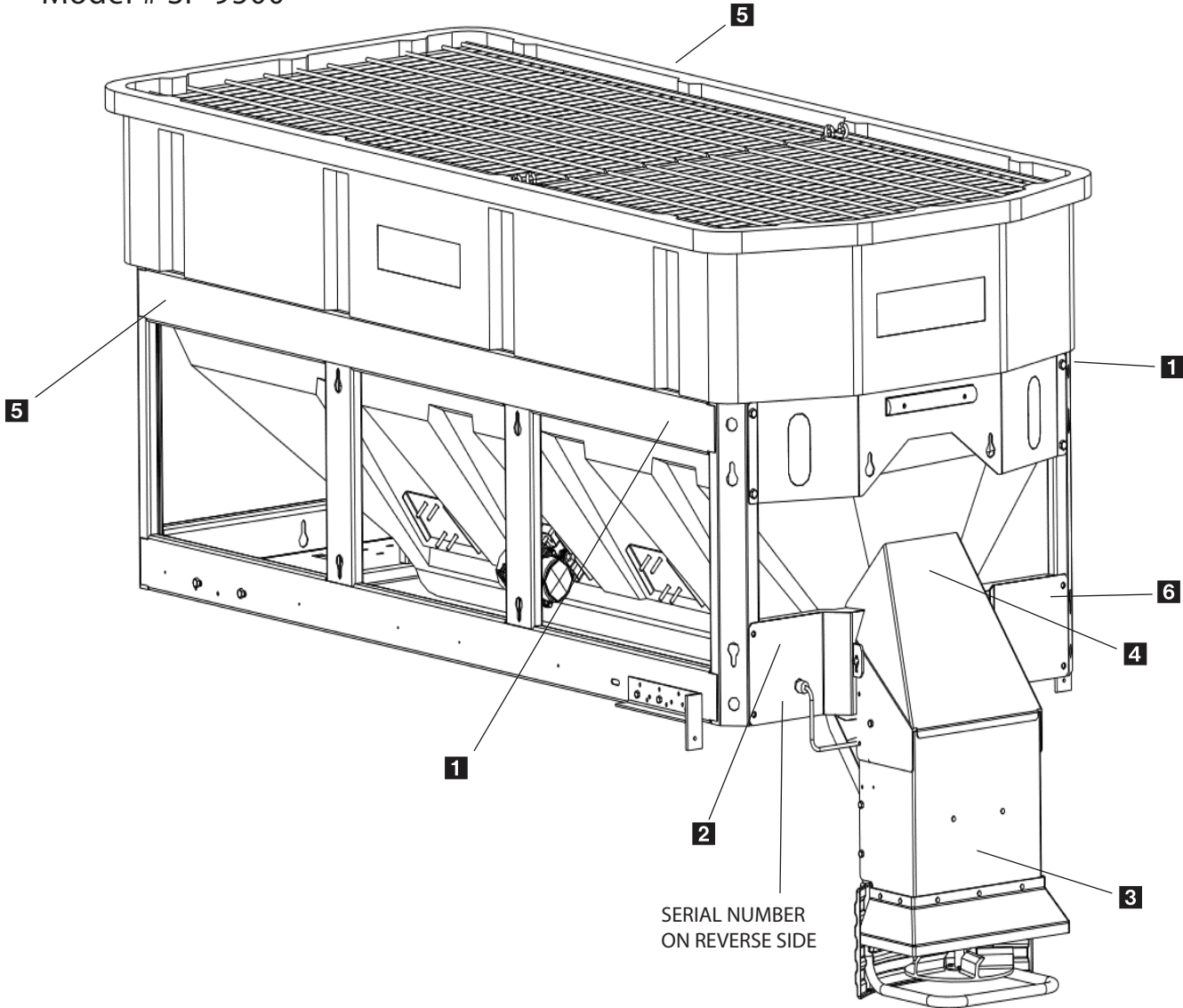

SERIAL NUMBER ON REVERSE SIDE



1 D 6546



2 D 6859



3 D 6545



4 D 6544

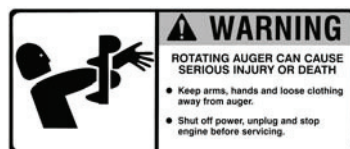

5 D 6335



6 D 6548

# Component Assembly Views

Model # SP-9500

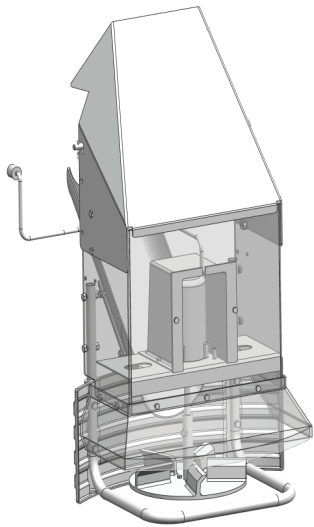

Spinner Drive Assembly

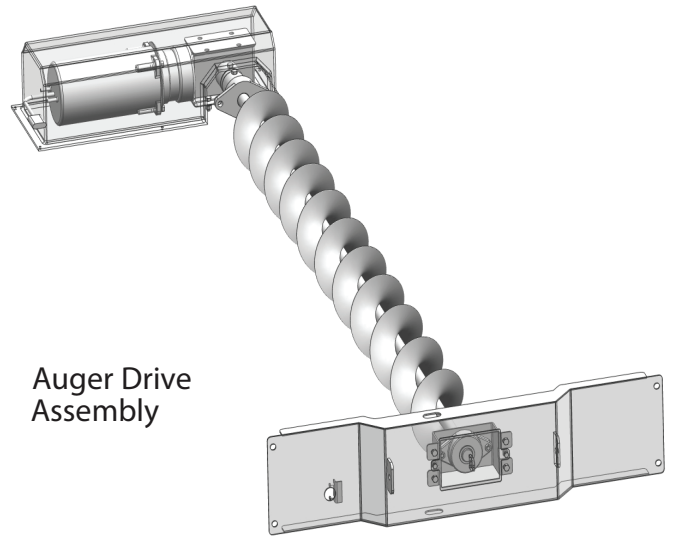

Auger Drive Assembly

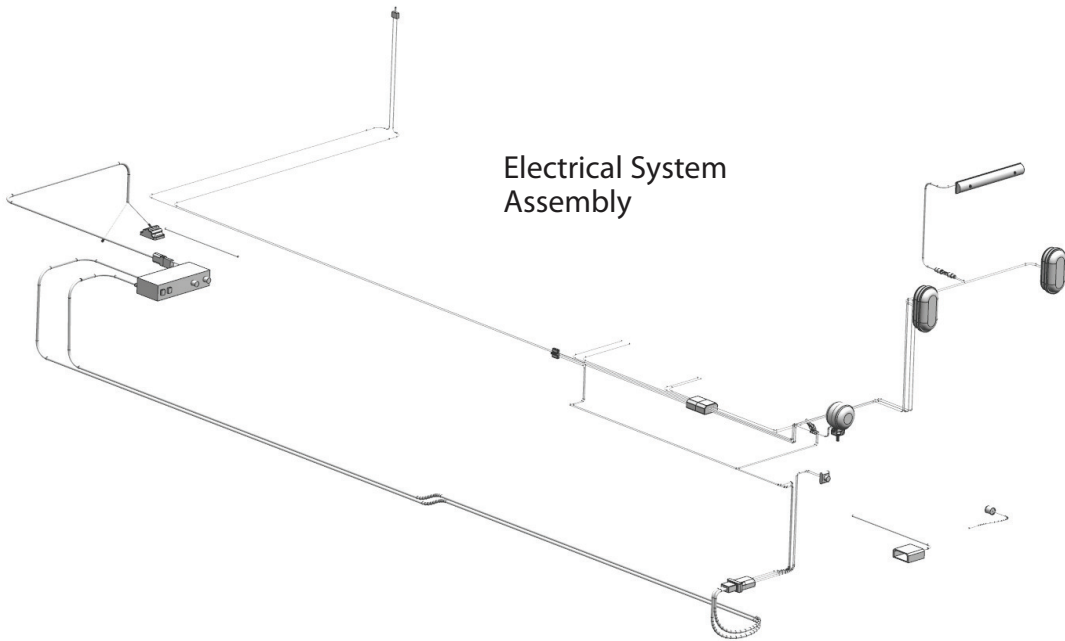

Electrical System Assembly

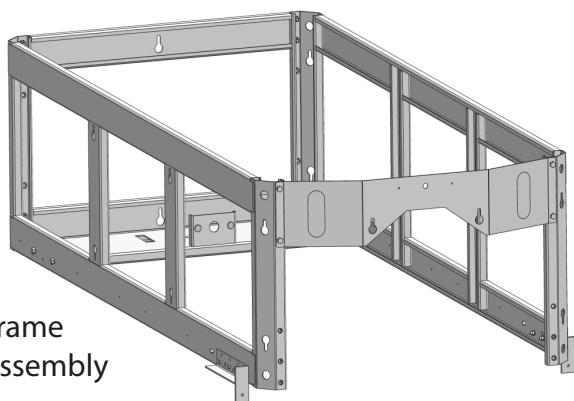

Frame Assembly

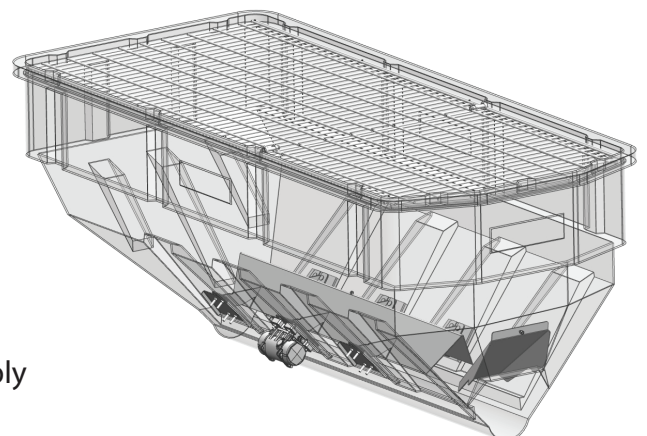

Hopper Assembly

# Side and Bottom Views

Model # SP-9500

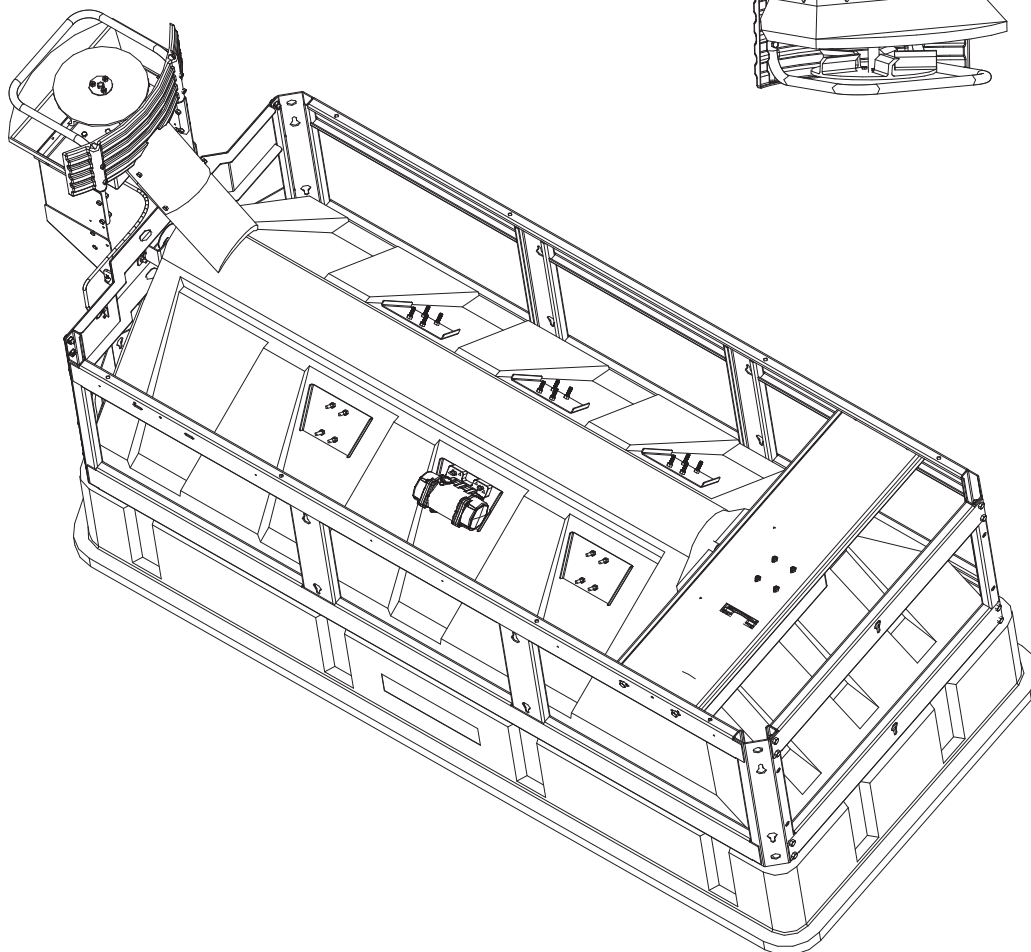
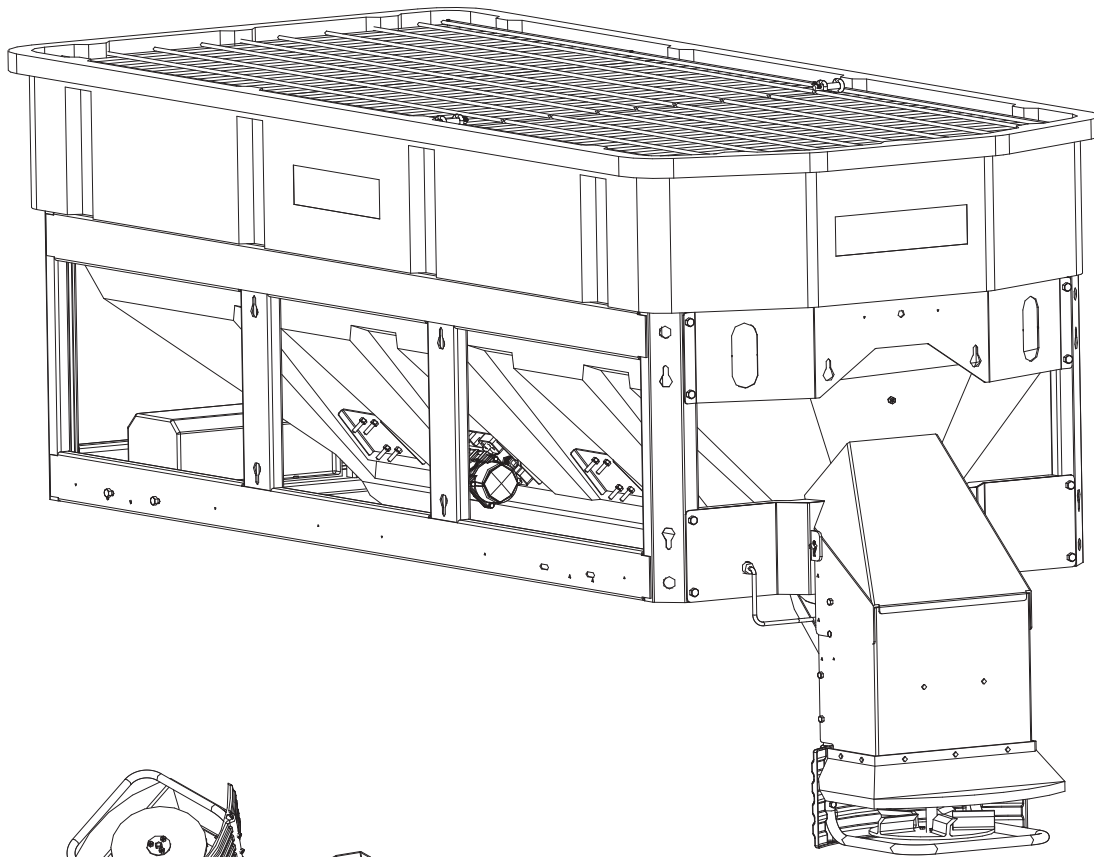

# Auger Drive Assembly Parts Breakdown

Model # SP-9500

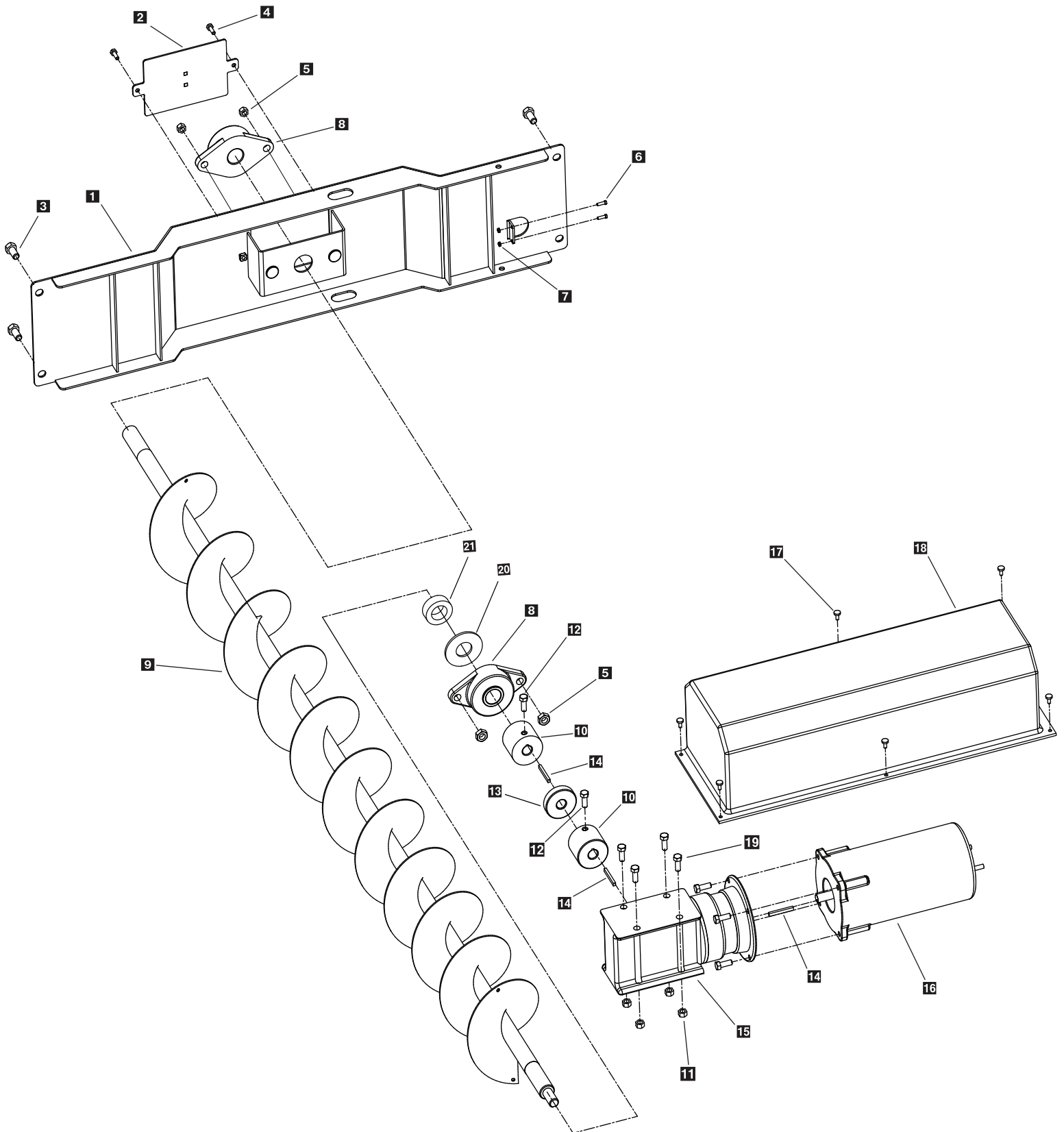

# Auger Drive Assembly Parts Breakdown

Model # SP-9500



Key	Part No.	Description	Qty.
<b>1</b>	D6881	Rear Spinner Drive Mount	1
<b>2</b>	D6814	Rear Bearing Cover Plate	1
<b>3</b>	D6528	1/2"-13 Serrated Hex Head Bolt	4
<b>4</b>	D6132	1/4"-20 x 3/4" Hex Head Bolt	2
<b>5</b>	D5535	1/2-13 Serrated Flange Nut	2
<b>6</b>	D6159	10-32 x 2" HH Machine Screw	2
<b>7</b>	D6158	10-32 Lock Nut	2
<b>8</b>	D6845	Auger Bearing	2
<b>9</b>	D6897	80" Auger Weldment	1
<b>10</b>	D6842	Transmission/Auger Coupler	2
<b>11</b>	D5706	5/16"-18 Serrated Flange Nut	4
<b>12</b>	INCLUDED	Coupler Set Screw	2
<b>13</b>	D6843	Urethane Coupler Spyder	1
<b>14</b>	D6873	3/6" Keyway Stock	3
<b>15</b>	D6894	Auger Transmission	1
<b>16</b>	D6872	9500 Auger Motor	1
<b>17</b>	D6877	#8 x 3/4" Driller With R-M Washer	6
<b>18</b>	D6868	Auger Motor Cover	1
<b>19</b>	D6576	5/16-18 x 1-1/4 Hex Head Bolt	4
<b>20</b>	D6789	Auger Shaft Hopper Washer	1
<b>21</b>	D6868	Auger Shaft Hopper Collar	1

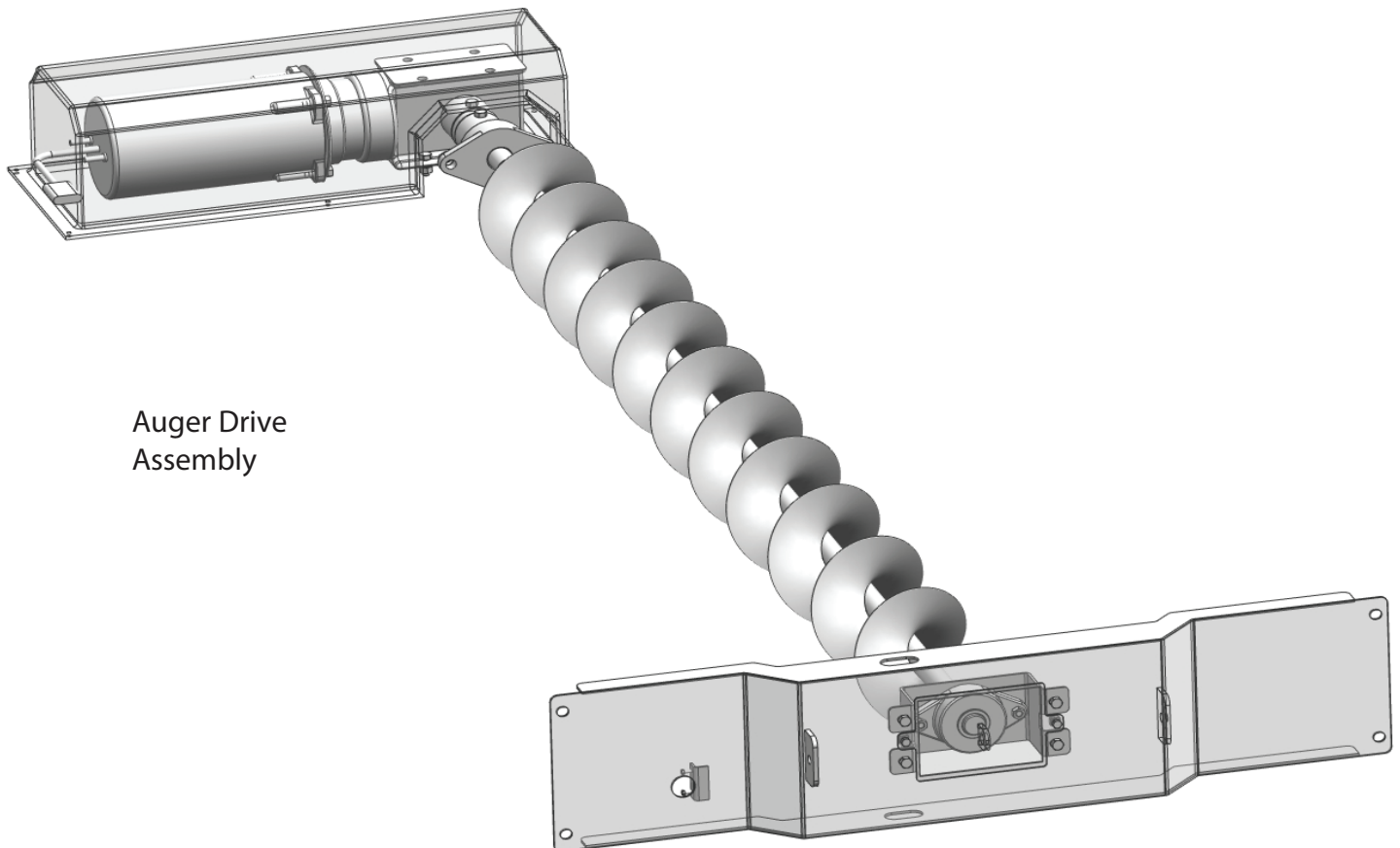

Auger Drive Assembly

# Spinner Drive Assembly Parts Breakdown

Model # SP-9500

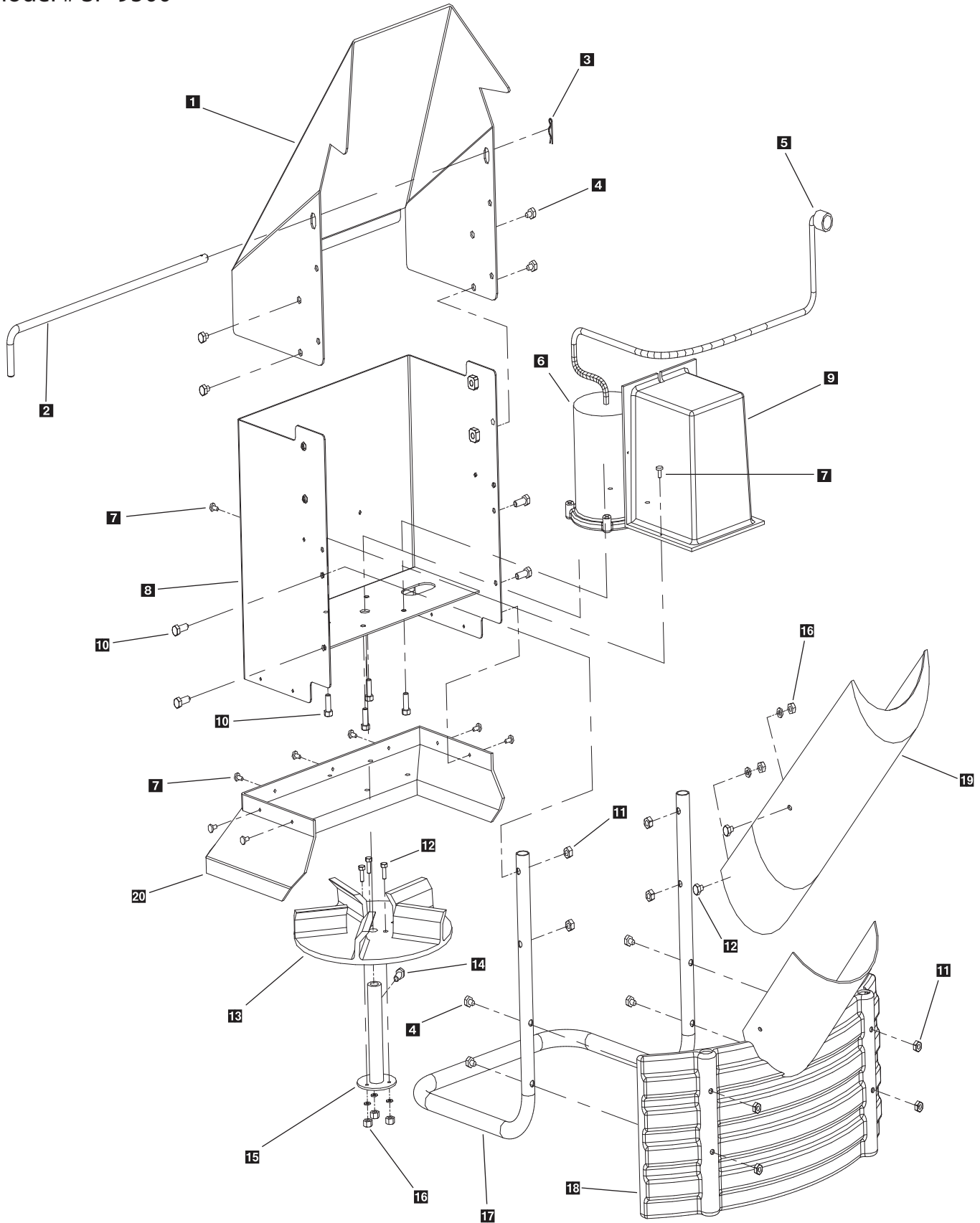

# Spinner Drive Assembly Parts Breakdown

Model # SP-9500



Key	Part No.	Description	Qty.
<b>1</b>	D6817	Spinner Shroud	1
<b>2</b>	D6563	20" Drive Mounting Pin	1
<b>3</b>	D4135	Drive Pin Clip	1
<b>4</b>	D6524	5-16"-18 x 1-1/2" Bolt	12
<b>5</b>	D6893	Spinner Power Plug	1
<b>6</b>	D6887	Direct Drive Spinner Motor	1
<b>7</b>	D6333	3/16" Long Rivet	9
<b>8</b>	D6867	10" Chute Extension	1
<b>9</b>	D6870	Spinner Motor Cover	1
<b>10</b>	D6452	3/8"-16 x 1" Serrated Type F	8
<b>11</b>	D6138	5-16"-18 Nylock Nut	4
<b>12</b>	D6854	1/4"-20 x 1" HWH Serrated SS	3
<b>13</b>	D6823	5 Flite Urethane Spinner	1
<b>14</b>	D6133	5-16"-18 x 1/2" Hex Head Bolt	1
<b>15</b>	D6891	Spinner Hub Weldment	1
<b>16</b>	D4289	1/4" Nylock Nut	5
<b>17</b>	D6820	Heavy Duty Spinner Tubular Guard	1
<b>18</b>	D6858	Plastic Spinner Deflector	1
<b>19</b>	D6885	Extended Plastic chute	1
<b>20</b>	D6859	Extended Plastic Spinner Guard	1

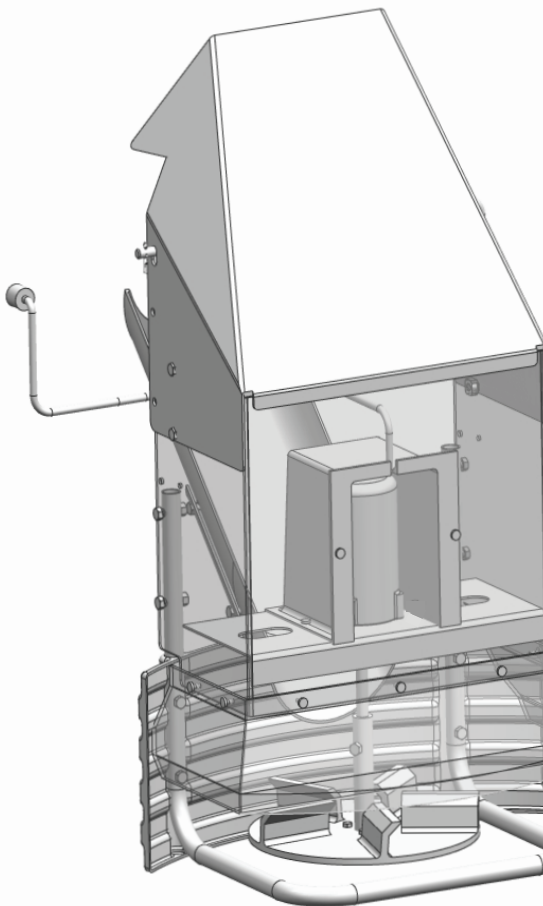

Complete Drive Assembly  
D6863

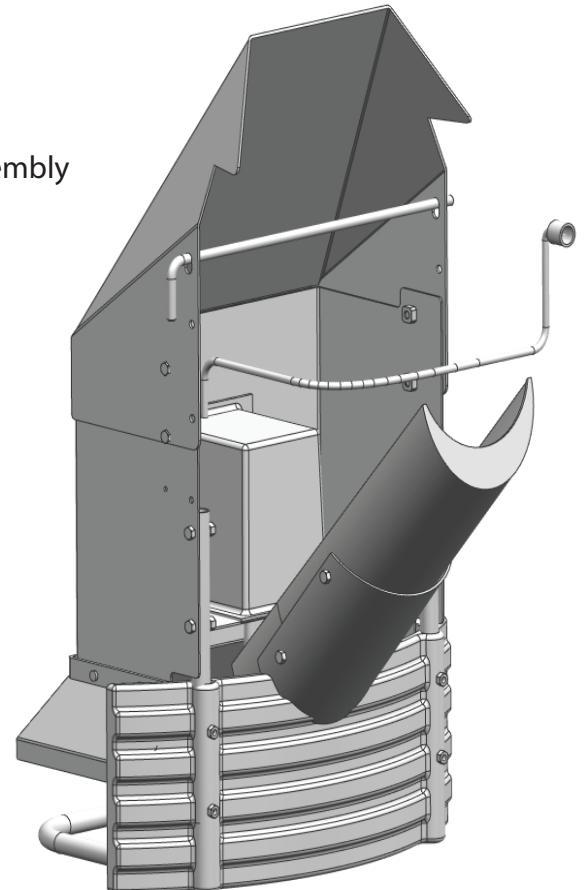

# Hopper Assembly Parts Breakdown

Model # SP-9500

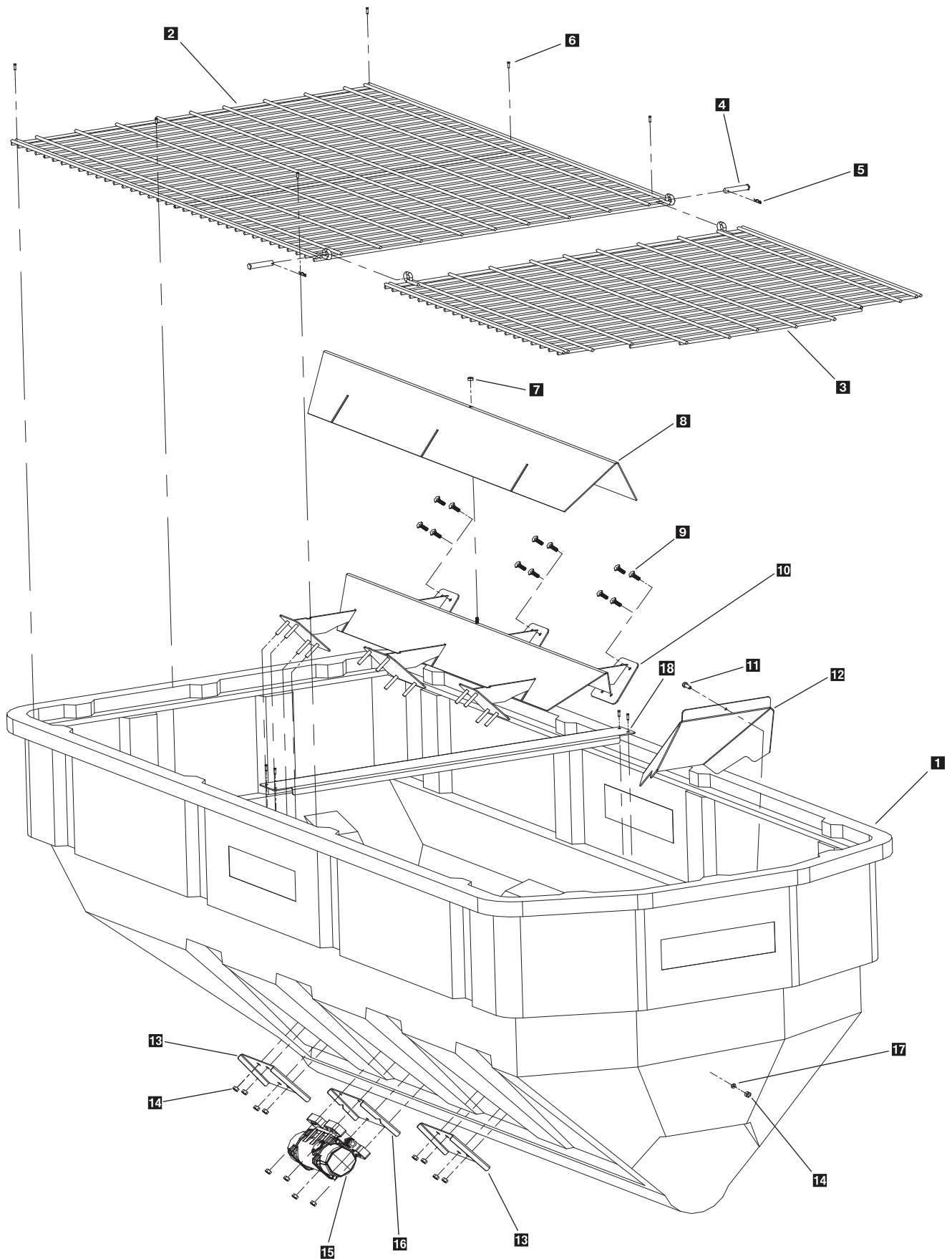

# Hopper Assembly Parts Breakdown

Model # SP-9500



Key	Part No.	Description	Qty.
1	D 6886	9500 Hopper	1
2	D 6890	Top Screen Front Section	1
3	D 6892	Top Screen Rear Section	1
4	D 6866	Top Screen Hinge Pin	2
5	D 4134	Top Screen Hinge Pin Clip	2
6	D 6874	1/4" x 1-1/2" Self Drilling Screw	10
7	D 6138	5/16-18 Lock Nut	1
8	D 6889	Inverted-V Salt Baffle	1
9	D 4122	3/8-16 x 1-1/2" HHCS	12
10	D 6888	Inverted-V Assembly	1
11	D 4121	3/8"-16 x 1" Hex Bolt	1
12	D 6869	Salt Discharge Baffle	1
13	D 6811	Inverted-V Backing Plates	5
14	D 4124	3/8"-16 Nylock Nut	25
15	D 6899	Heavy Duty Vibrator	1
16	D 6860	Vibrator Backing Plate	1
17	D 4125	3/8" Flat Washer	1
18	D 6898	Hopper Cross Bar Support	1

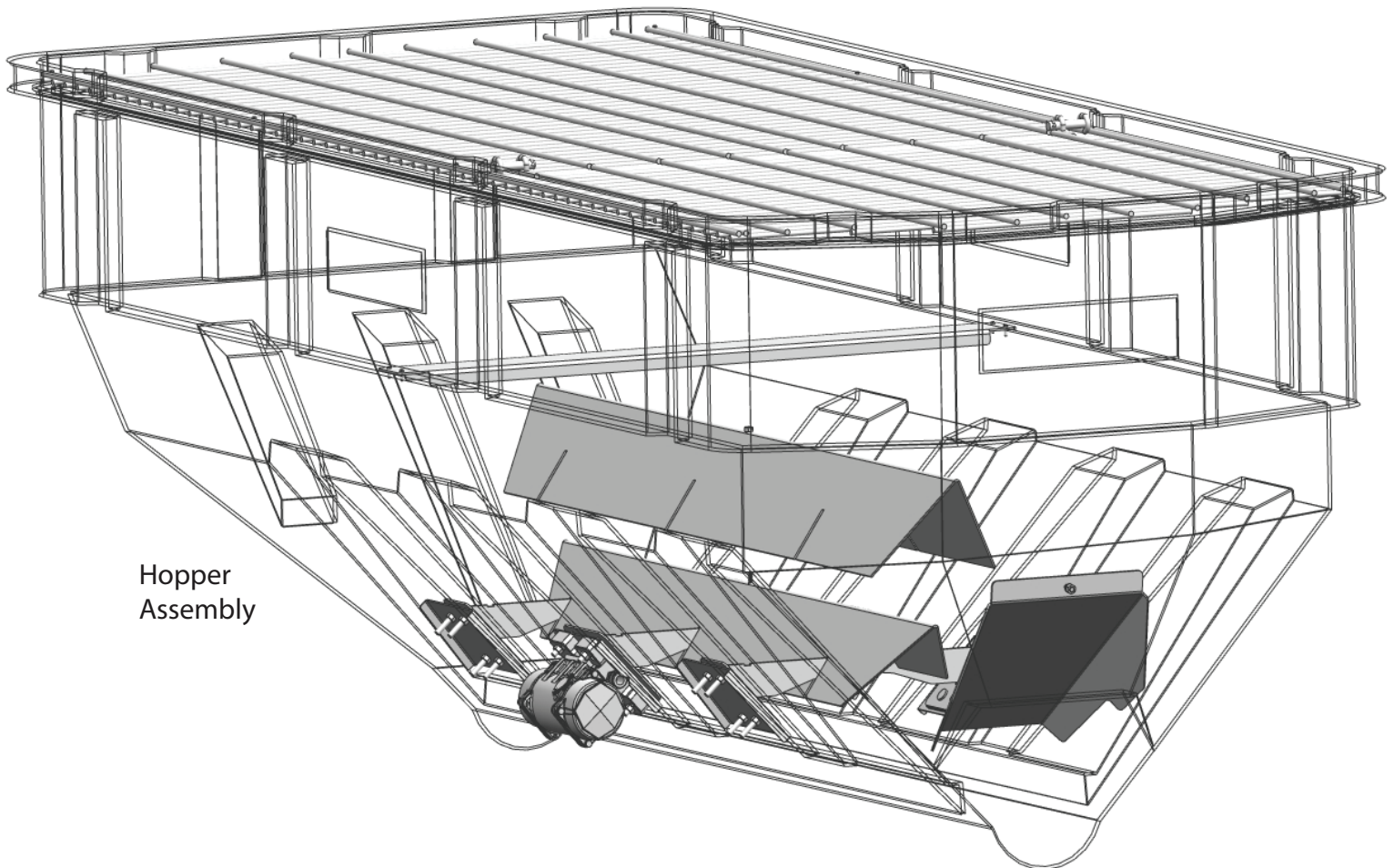

Hopper Assembly

# Frame Assembly Parts Breakdown

Model # SP-9500

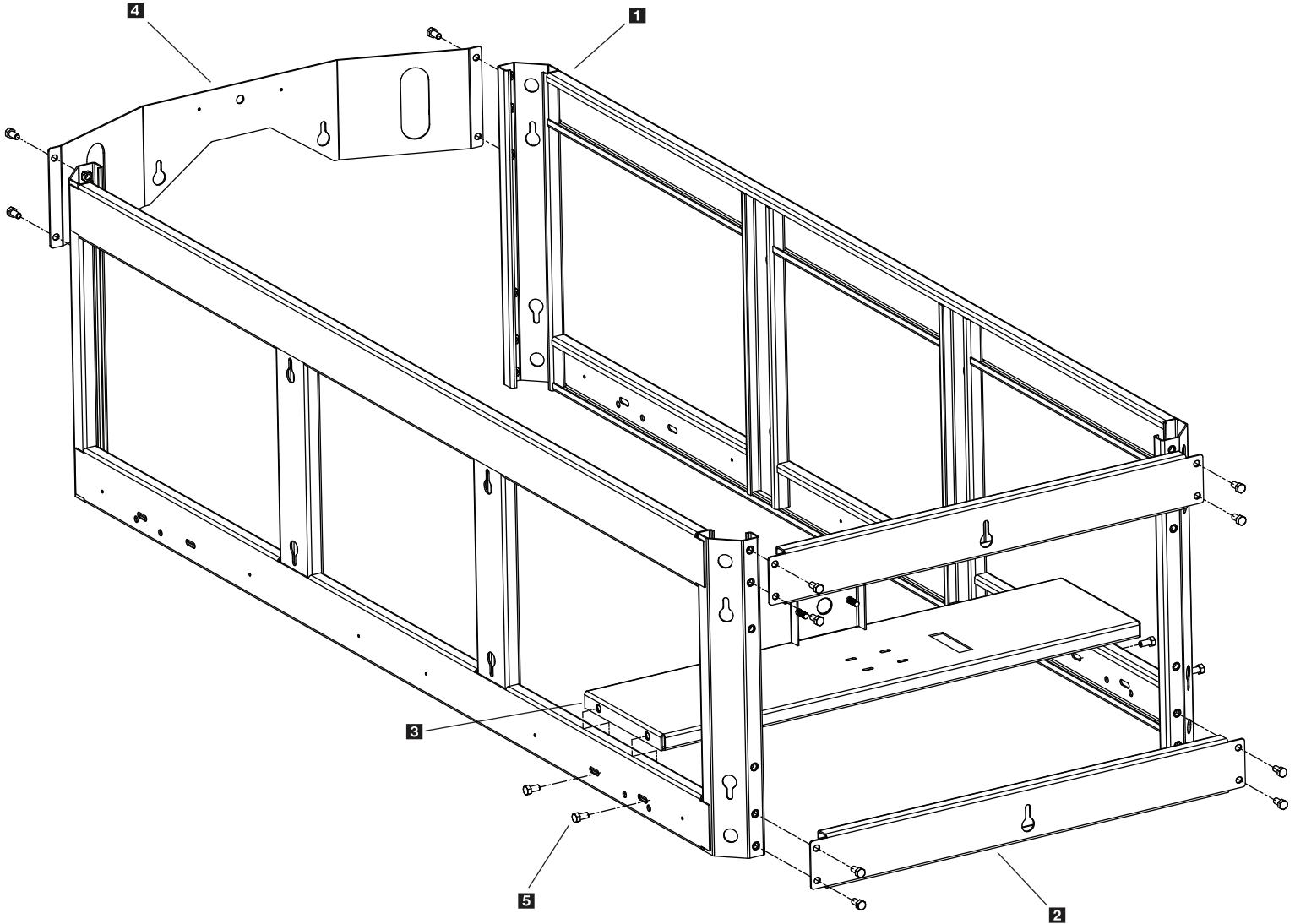

# Frame Assembly Parts Breakdown

Model # SP-9500



Key	Part No.	Description	Qty.
1	D 6879	9500 Frame Weldment	2
2	D 6882	Upper/Lower Front Rail	2
3	D 6884	Auger Motor/Transmission Support	1
4	D 6880	Rear Apron With Light Hole Knock Outs	1
5	D 6528	1/2"-13 x 1" Serrated Hex Head Bolt	16

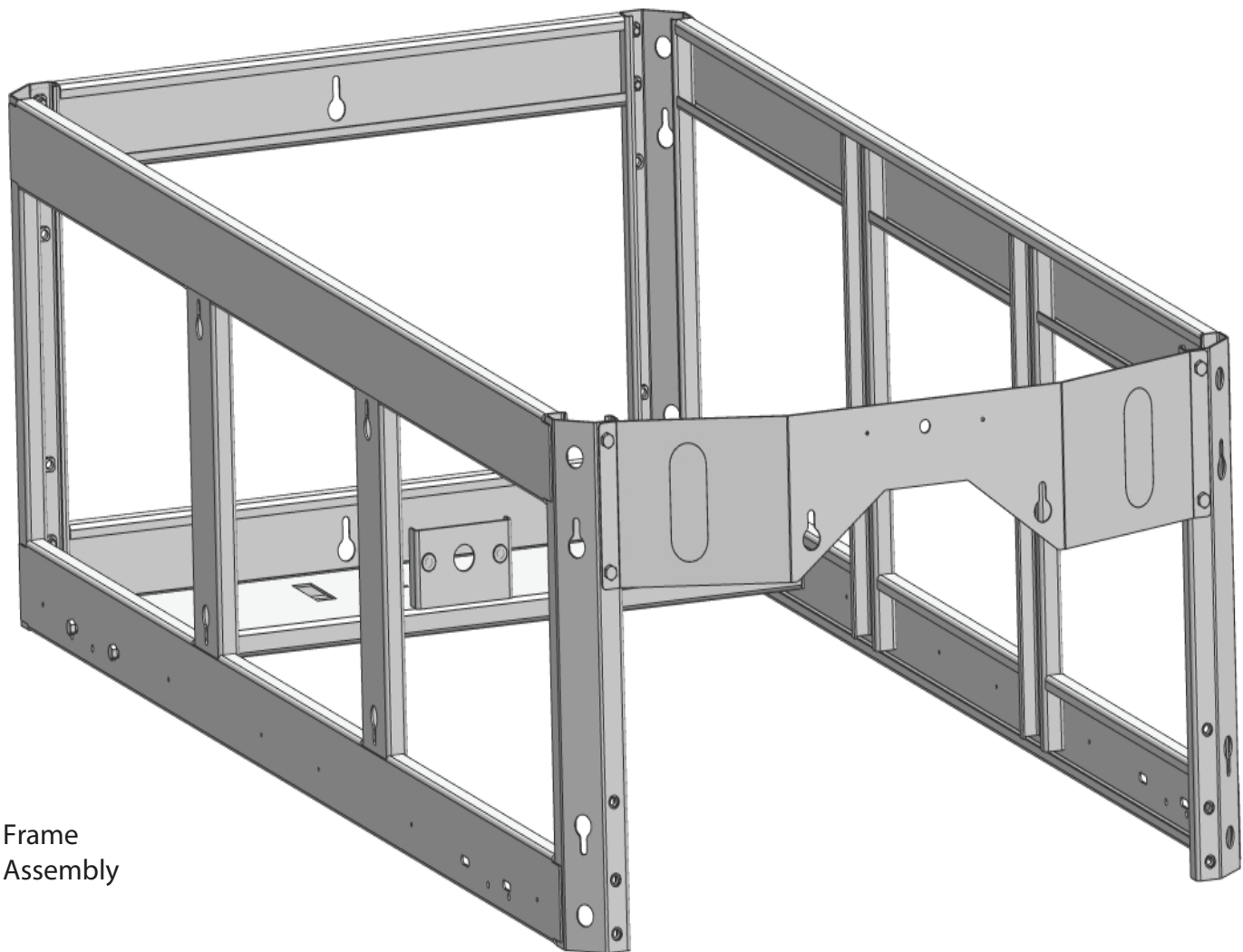

Frame  
Assembly

# Vehicle Harness Wiring Instructions

Model # SP-9500

Step 1: Take harness assembly and route from the rear of the vehicle to the front. Route harness along frame and attach to frame hole and frame supports. It is not recommended to attach to fuel or brake lines for obvious reasons. Do not route close to exhaust system or engine, even though Snowex uses high temperature wiring. It still could melt under extreme heat and short the spreader electrical system, as well as the vehicle electrical system.

Step 2: Mount rear plug on bumper using supplied bolts, locate towards the center of the bumper to reduce the amount of debris the tires will throw to the rear. Important: Apply a small amount of dielectric grease to the plug. Also try to mount so plug faces upward to help keep plugs tightly sealed.

Step 3: Secure harness from the rear to the front using heavy duty ty-wraps or frame clips along the frame and lighter duty ty-wraps everywhere else.

Step 4: Layout harness portion that connects to the battery along the fire wall and fender well. Do not connect power leads to battery yet. Drill a 3/4" hole in the fire wall, or use existing access hole, for the control portion of the harness and route connector and harness through hole. Be sure to check the area on the other side of the fire wall to make sure you are not drilling into the vehicle harness or a control module. Generally you can drill on either side of the steering wheel for a good location.

Step 4A: The power harness from control box to battery will need to be routed from the inside of the cab to the battery – this results from the large high amperage connector. Route leads with lugs to battery — do not connect power at this time.

Step 5: Connect harness to the back of the controller and mount to a suitable location. NOTE: You may want to contact customer before mounting controller as some prefer not to have holes drilled into the dashboard. Ty-wrap loose controller harness and move to the engine compartment. Do not mount close to any heater vents.

Step 6: Connect power leads to the battery: Red + Positive, Black – Negative, always connect to the primary battery if using a dual battery system. Secure loose loom to any other large or medium vehicle harness with medium duty ty-wraps; this will secure wiring harness.

Step 7: Push the ON/OFF button on the controller to check for power; when that has been confirmed, turn power **OFF**. The electrical portion of the installation is complete.

# Electrical System Parts Breakdown

Model # SP-9500

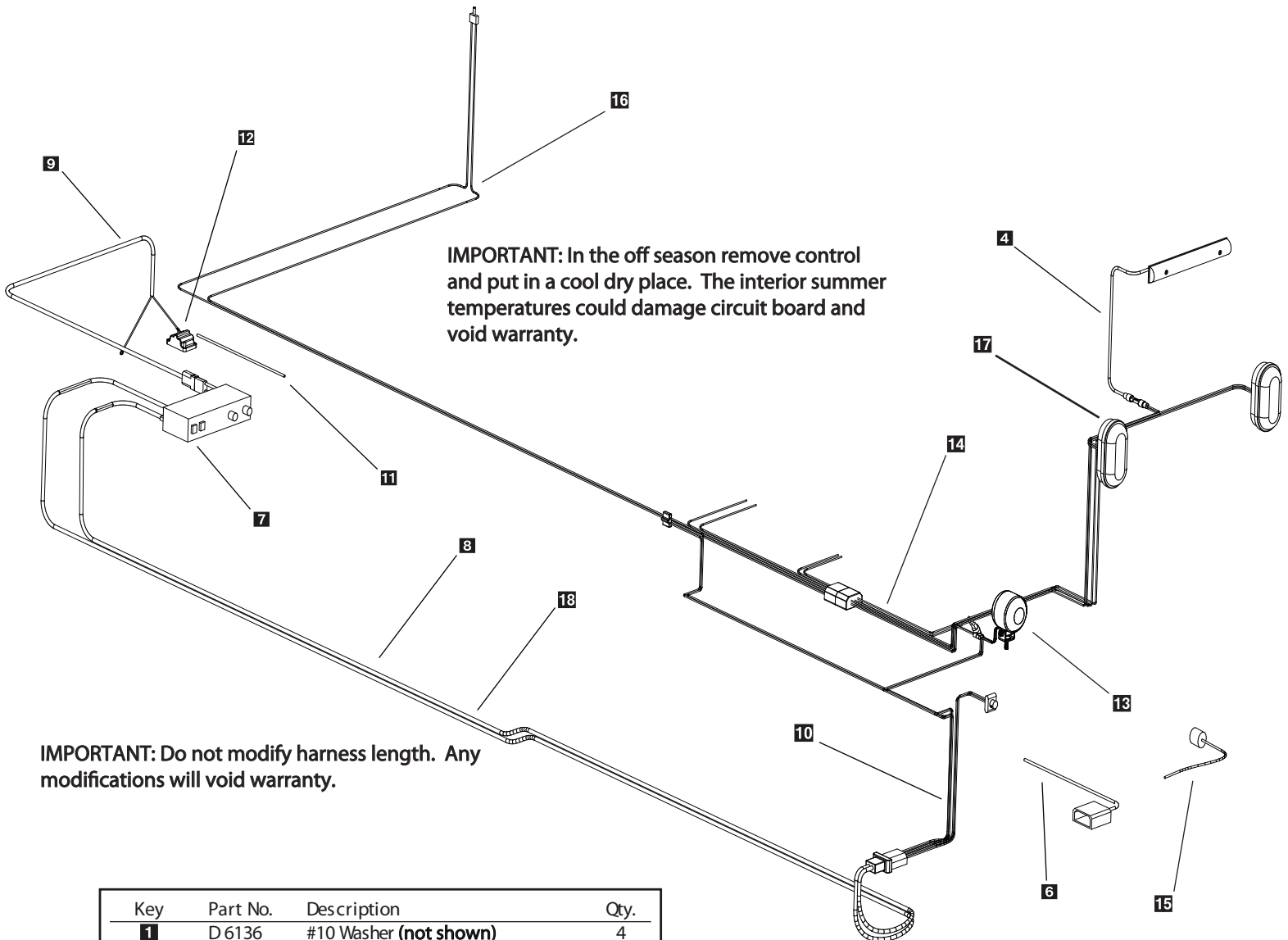

**IMPORTANT:** In the off season remove control and put in a cool dry place. The interior summer temperatures could damage circuit board and void warranty.

**IMPORTANT:** Do not modify harness length. Any modifications will void warranty.

Key	Part No.	Description	Qty.
1	D 6136	#10 Washer <b>(not shown)</b>	4
2	D 6158	#10 Lock Nut <b>(not shown)</b>	4
3	D 6874	#14 x 1.5" HWH Screw <b>(not shown)</b>	4
4	D 6514	CHMSL Light Assembly	1
5	D 6529	#10 Machine Screw <b>(not shown)</b>	2
6	D 6118	Dust Cap Light Kit/Spreader	2
7	D 5716	V-Maxx Dual Control	1
8	D 6836	27' Vehicle Harness	1
9	D 6837	Control Power Cable	1
10	D 6895	Spreader Harness	1
11	D 6839	6 GA. Breaker Wire	1
12	D 6851	100 AMP Resettable Breaker	1
13	D 6784	Work light	1
14	D 6787	Work light Spreader Harness	1
15	D 6118	Spreader Spinner Dust Cap	1
16	D 6786	Light Kit Vehicle Harness W/Switch	1
17	D 6788	Amber Led Strobe Light	2
18	D 6896	30' Vehicle Harness <b>(optional)</b>	1
19	D 6170	Anderson Connector With Leads	1

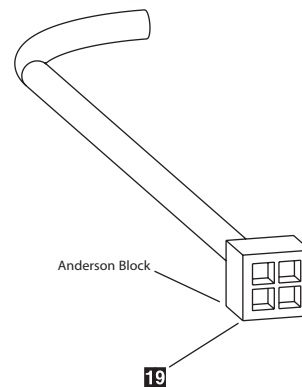

# Controller Wiring Diagram

Model # SP-9500

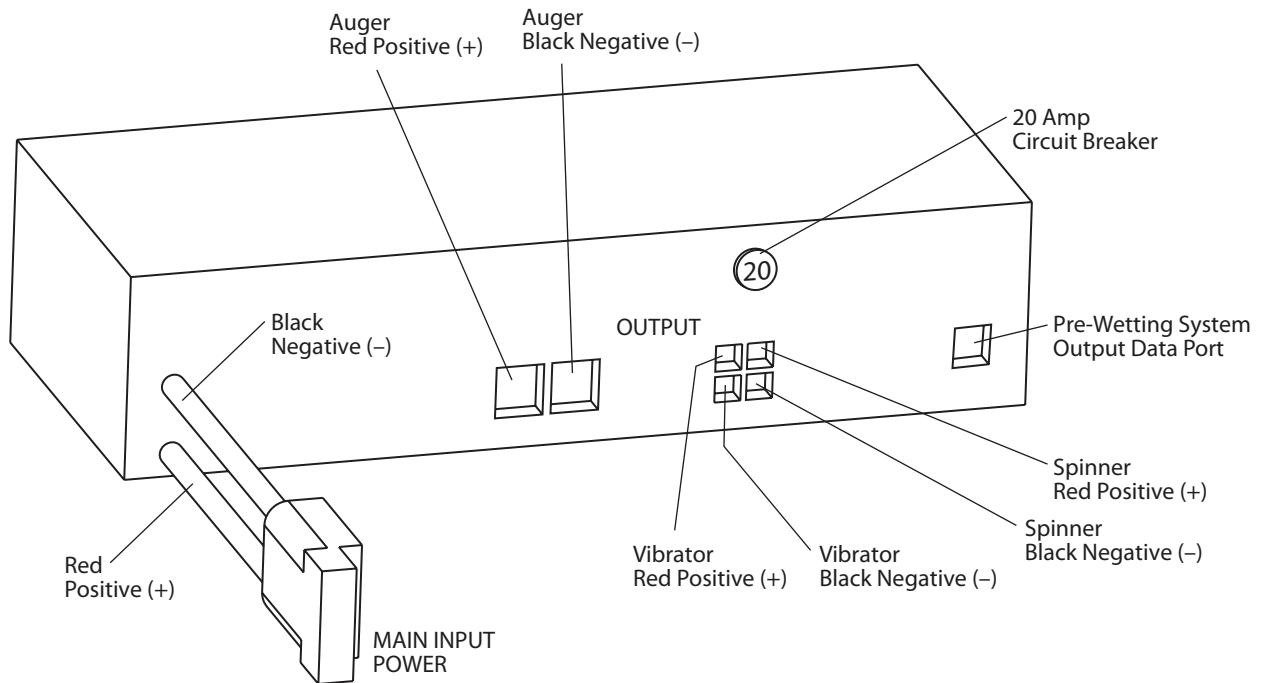

**IMPORTANT:** In the off season remove control and put in a cool dry place. The interior summer temperatures could damage circuit board and void warranty.

## Control Power Cable

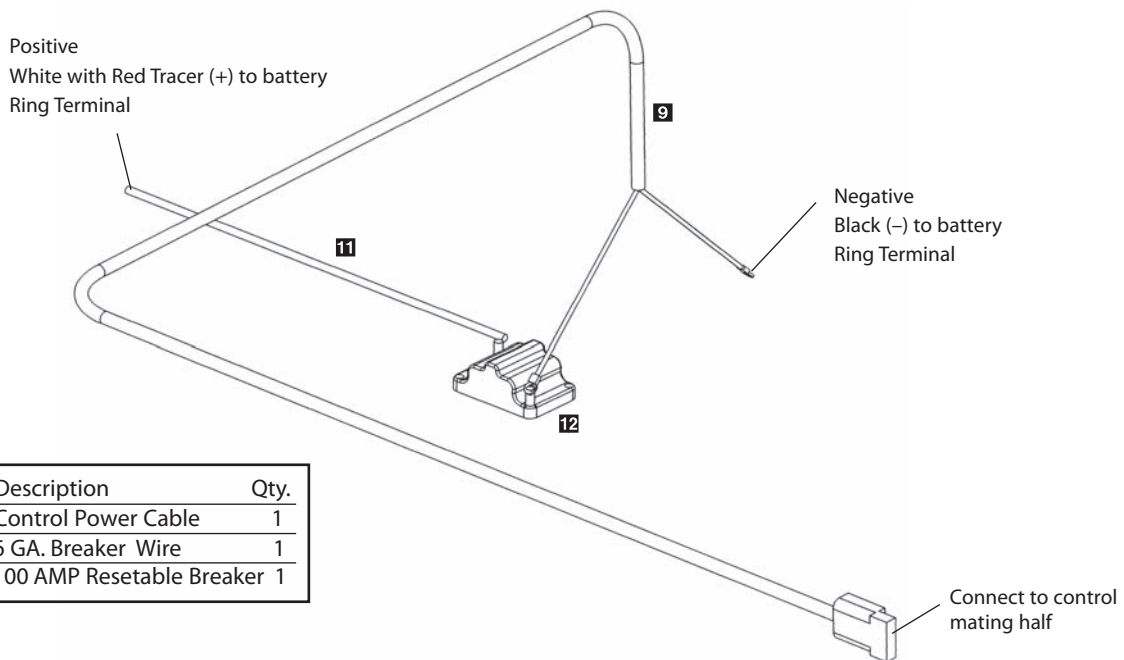

Key	Part No.	Description	Qty.
9	D 6837	Control Power Cable	1
11	D 6839	6 GA. Breaker Wire	1
12	D 6840	100 AMP Resettable Breaker	1

\* NOTE:

- A) Leads must only be attached to battery.
- B) 100 Amp breaker must be inserted.

# Spreader Power Harness Circuit Diagram



Model # SP-9500

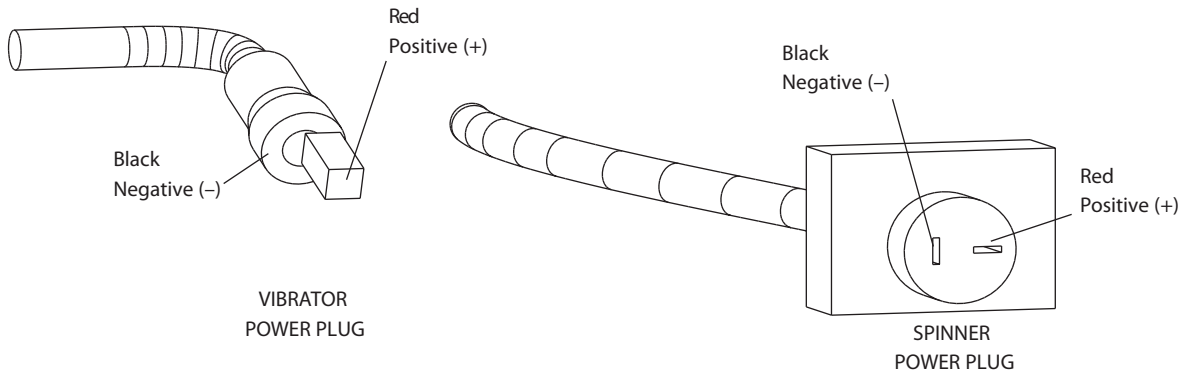
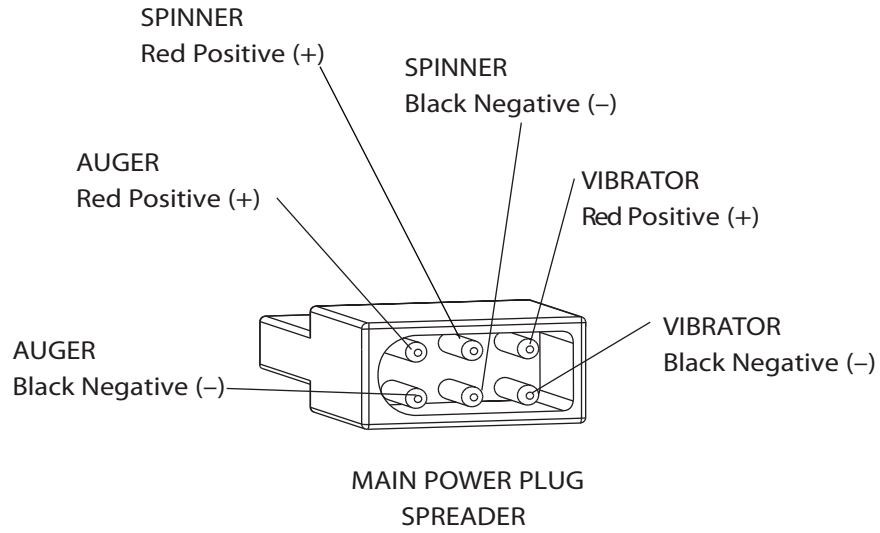

# Vehicle Harness Circuit Diagram

Model # SP-9500

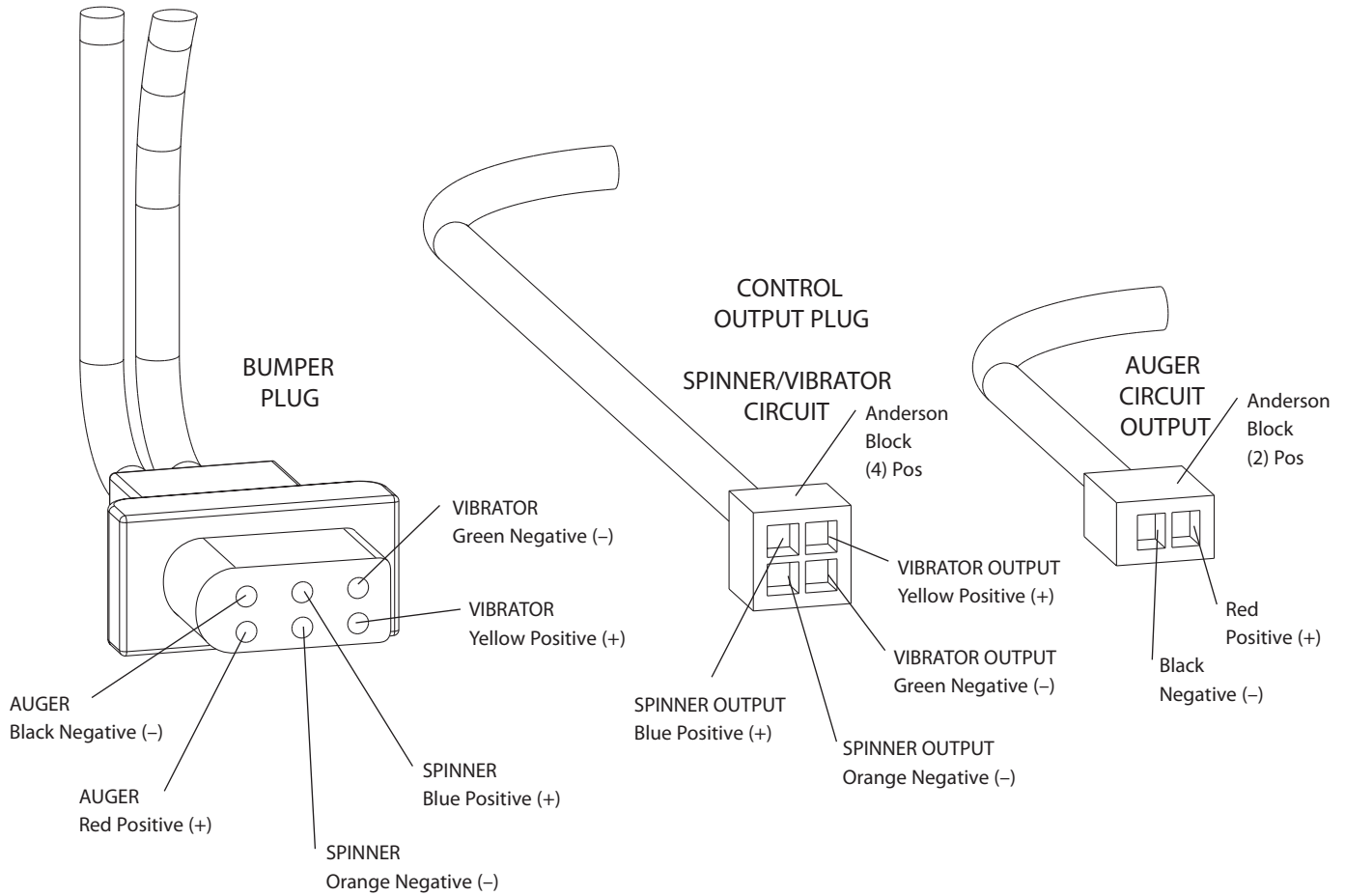

\* NOTE: Reference Bumper Plug for Color Code

# Mounting Kit Parts Breakdown

Model # HMK-175

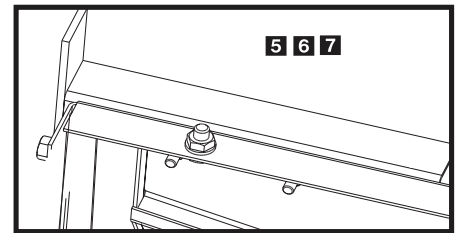
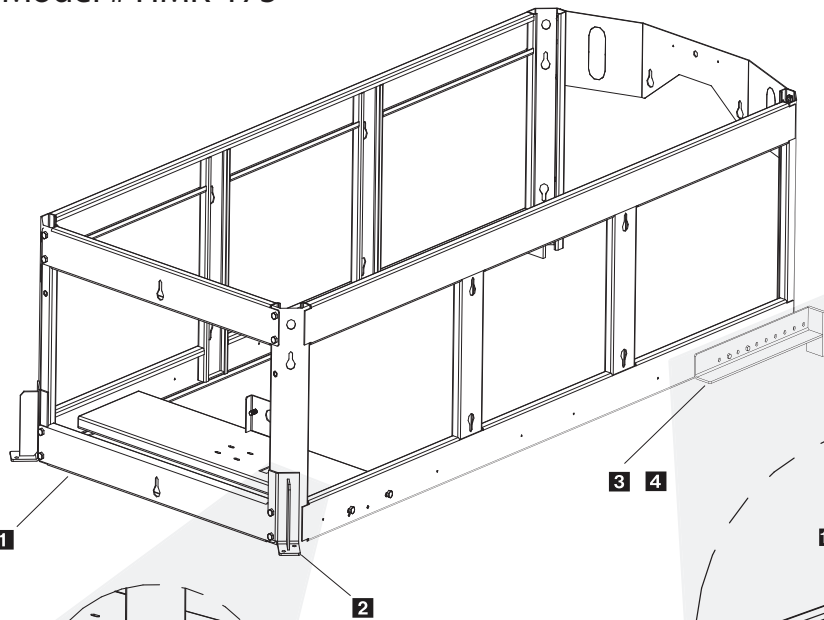

Figure 2: Frame Mounting Bolts

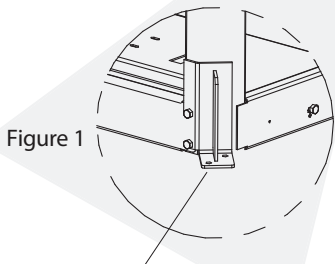
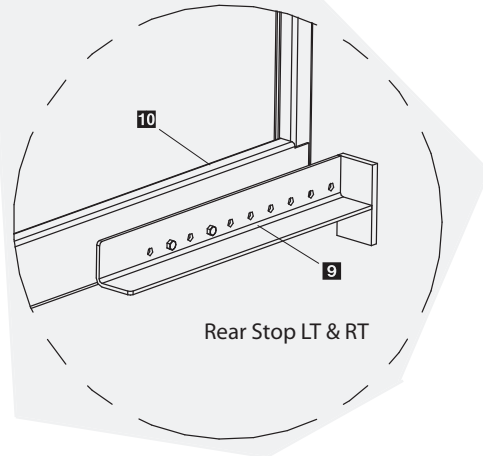
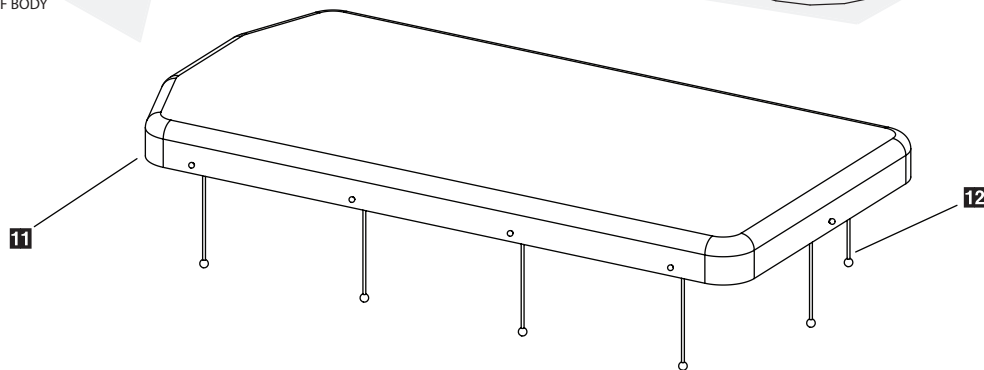

Figure 1

BOLT THROUGH FLOOR OF BODY



Rear Stop LT & RT



Key	Part No.	Description	Qty.
1	D 6756	Adj. Stop Bracket Rt Rear	1
2	D 6755	Adj. Stop Bracket Lt Rear	1
3	D 6759	Left Front Stop Bracket	1
4	D 6760	Right Front Stop Bracket	1
5	D 4120	1/2" Lock Nut	8
6	D 4116	1/2"-13 x 1-1/2" Hex Bolt	8
7	D 4119	1/2" Flat Washer	8
8	D 6758	Ratchet Strap	4
9	D 4121	3/8"-16 x 1" Lock Nut	4
10	D 4124	3/8" Lock Nut	4
11	D 6883	Tarp	1
12	D 6522	Bungie Tie Downs (13 Per Pkg)	1

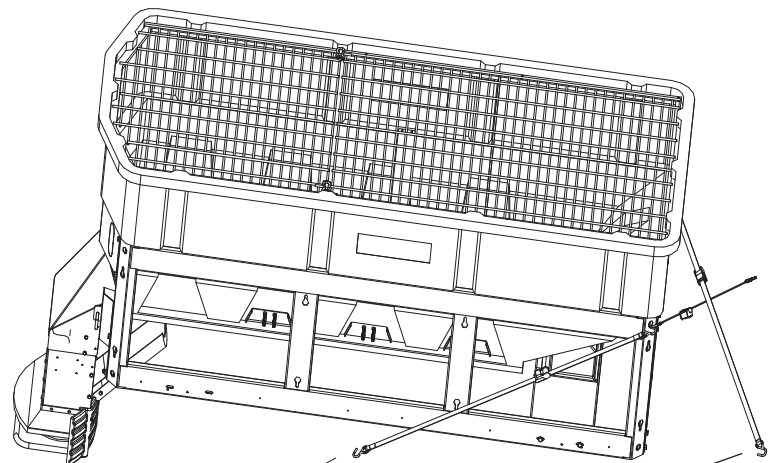

8 CROSS FRONT STRAPS AS SHOWN

# Mount Kit Mounting Instructions

Model # HMK-175

Step 1: For dump trucks remove tailgate, and for platform bodies remove rear racks.

Step 2: Load spreader on to truck bed and mount spinner assembly.

Step 3: Slide spreader forward until deflector/chute assembly makes contact with vehicle. Then, slide spreader back approx. 1" to allow for proper clearance.

Step 4: Install rear stop bars using supplied hole patterns (see Fig.2). To achieve the best position, you may need to drill additional holes in bracket in order to properly position spreader.

Step 4-A: Install front stops using supplied hole patterns (see Fig.1). You will need to bolt through the body.

Step 5: Now that the spreader is positioned front to back, you will now center it left to right. Looking at the inside front and rear corner of the lower frame area, you will notice (4) holes in the bottom of the frame. Using a paint pen or similar marking device, mark hole locations.

Step 6: Before drilling holes, look beneath the approximate area where each hole will be located. Make sure there are no vehicle components that will be in the path of the drill before doing this step. If there are interferences, you can relocate holes as needed making sure there are at least two forward and two rearward of the front to back centerline.

Step 7: Install and tighten all (4) bolts. (see Fig.2)

Step 8: Install ratchet straps (see V-Maxx 9500 Mounting System: Strapping Techniques). It is very important for everyone's safety this strapping method be used as the standard mounting procedure. **NOTE: (Do not use ratchet straps exclusively.)**

Step 9: Connect the spreader power cord to vehicle main power plug mounted at rear of vehicle (see Electrical Installation).

# Mounting Instructions

Model # SP-9500



## Recommended Installation For Platform Bodies

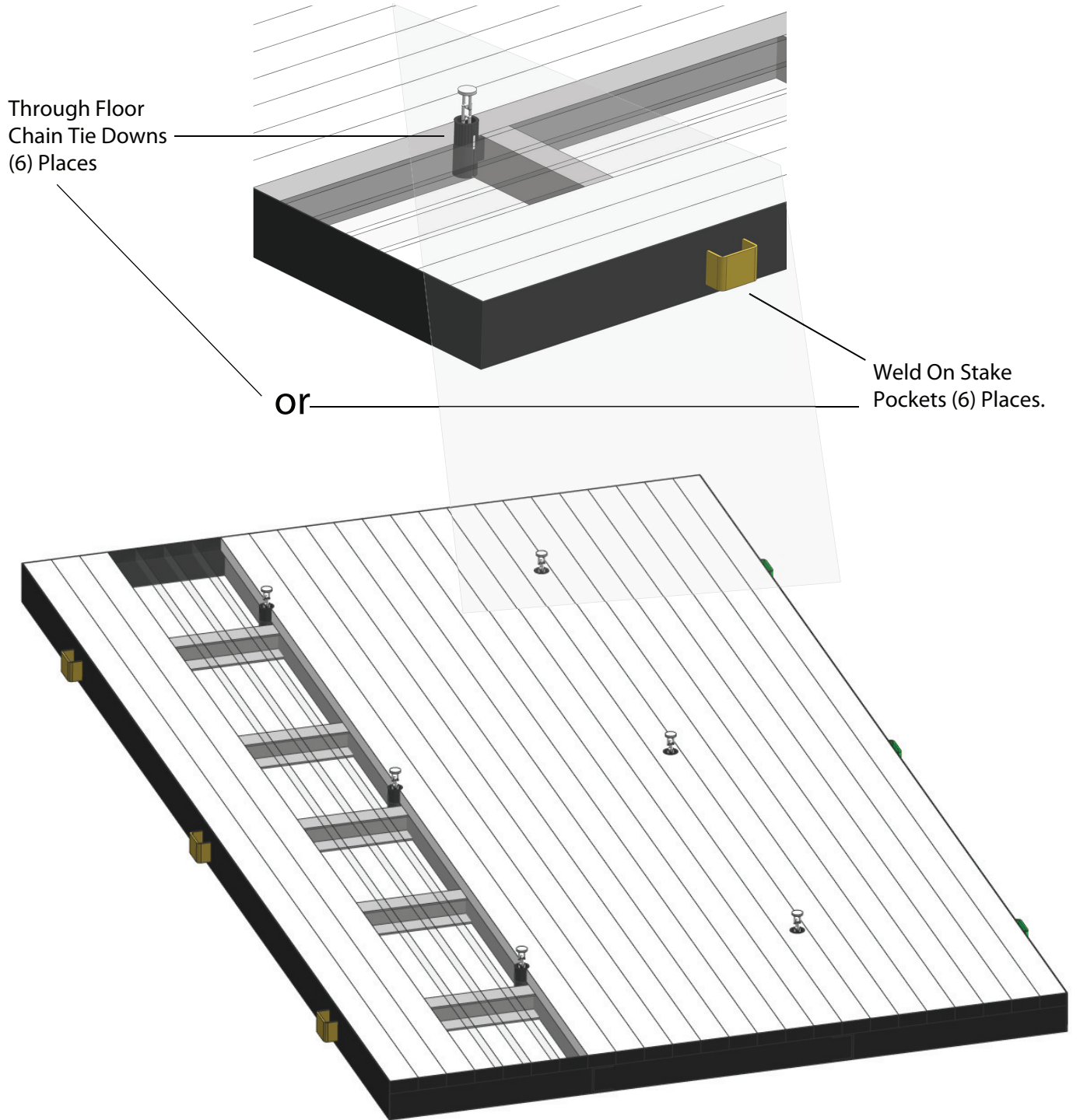

# Operating the Spreader

## Model # SP-9500

### PREPARATION

CAUTION – Sweep area clear of foreign objects or obstacles that could cause personal injury. Keep other persons, children, or animals out of the area to be spread.

### SPREADER LOADING

WARNING –Do not overload vehicle. Use chart below to calculate weight of material. Weights of material are an average for dry materials.

<u>Material</u>	<u>Weight Per Cubic Ft.</u>
Rock Salt	35-40 lbs.
Sand/Salt Mix	95-120 lbs.

- Be sure to comply with manufacturer's maximum gross vehicle weight ratings.
- Warning– Never leave material in hopper for long periods of time as salt is hygroscopic and will attract atmospheric moisture and harden up. When spreading sand mix, a 1:1 ratio for Sand/Salt mix is recommended to prevent the material from freezing.

### SPREADING TIPS

- Never exceed 10 m.p.h. when spreading.
- For a wider pass, increase spinner speed.
- For a heavier pass, drive slower, or increase auger speed.
- Never operate spreader near pedestrians.
- Spread ice melters with the storm to prevent unmanageable levels of ice.
- Calculate spread pattern when near vegetation.

### V-Maxx 9500 CONTROL OPERATION

- The Dual Variable Speed Control has dual finger-tip dials for maximum performance, digital system status with warning protection and built-in vibrator switch.
- To start, press power switch on controller and spreader will accelerate to speed set on spinner and auger dials.
- To stop, press power switch on controller to off position.
- Speed of auger and spinner may be adjusted separately to get desired flow and spread distance from spreader.
- The Vibrator Switch is needed for dense material or to increase the flow to the auger. This eliminates bridging of material in hopper.
- In case spreader becomes jammed, it will go into an auto-reverse program to free itself. Auger display will show (AR) while trying to clear obstruction.

## Operating the Spreader (continued)

Model # SP-9500

### WARNING PROTECTION

- If audible beeping occurs, read display to identify problem. If display reads “OL” (overload) or “OH” (overheat), shut controller down and carefully clear jammed auger. If display reads “E1” this means there is a dead short in system. Do not use until problem is corrected. If display reads “E 0” this means that the motor is not getting any power. Check all connections. If display reads “LB” the vehicle battery is extremely low (possibly caused by a poor or corroded connection) and could damage the system.
- If there are any problems while operating the spreader, refer to Troubleshooting Guide.

### AUTO-REVERSE “AR” FUNCTION

- If your controller displays “OL” this could indicate a jammed auger.
- To engage the Auto-Reverse “AR” function:

Step 1: Shut the Main Power Switch OFF for 3 seconds.

Step 2: Turn the Main Power Switch ON. When the machine starts back up the “AR” sequence will automatically start and the auger will reverse for several rotations to clear the jam.

- After a pause of several moments, the auger will automatically return to correct rotation.
- If the jam is still not cleared, the controller will again display “OL”.
- You may repeat Steps 1 & 2 for a second and third time.
- If after the third try the controller displays “OL” — you must extract the material that is causing the problem.
- Follow all warning directions when clearing jams.

D6889

### BAFFLE INSTRUCTIONS

- The V-Maxx 9500 uses a dual baffle design over the auger area. This baffle (D6889) is used for dry bulk materials. The baffle is designed to reduce the risk of leakage with clean/dry free-flowing materials. If the material you are using is damp/wet, you may need to remove baffle (D6889). This will allow for more un-restricted flow of materials and possible bridging.
- **WARNING:** Always disconnect power source before attempting to remove material baffle.
- The main baffle assembly (D 6888) **MUST** never be removed from its original factory installed position unless the unit is being serviced or for installing the Optimum flow Kit.

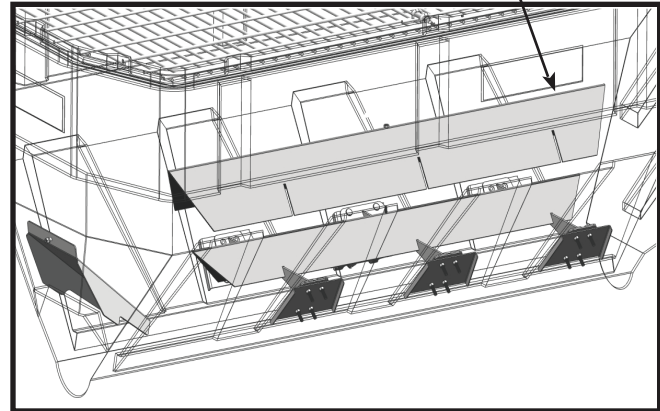

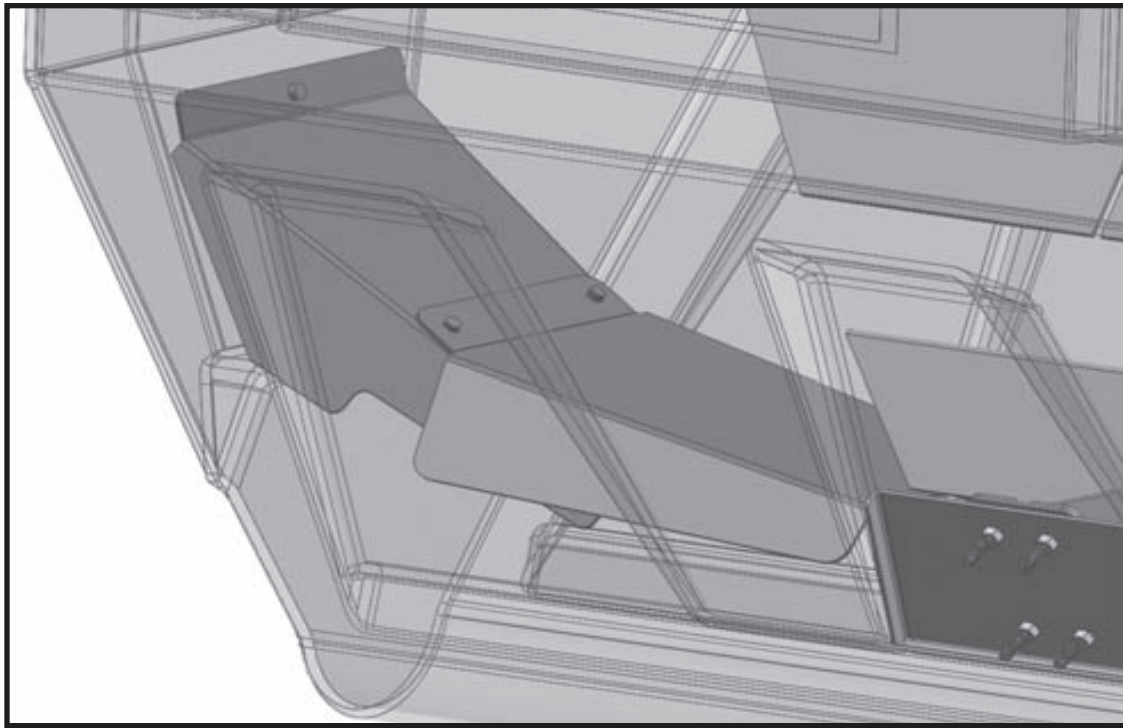

## BAFFLE EXTENSION INSTRUCTIONS

- The Baffle Extension (**D6776**) is intended to be used with very dry products that free-flow with little effort. The baffle is designed to keep these types of materials from leaking out.
- If you plan on using damp/wet materials, you should remove this baffle by removing the self-drilling screws.
- If you are using a sand/salt mixture, remove baffle extension.

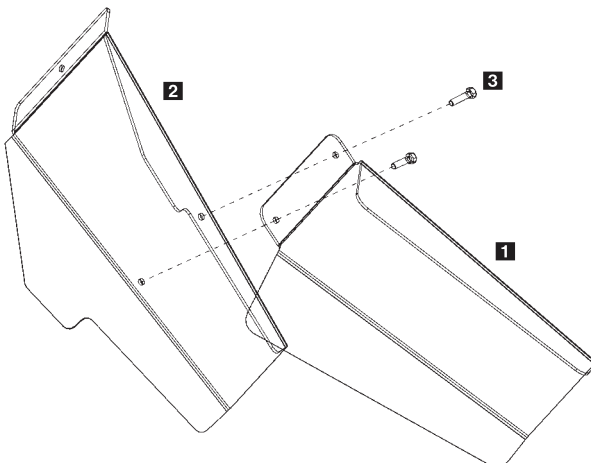

Key	Part No.	Description	Qty
<b>1</b>	D 6776	Salt Baffle Extension	1
<b>2</b>	D 6869	Discharge Baffle	1
<b>3</b>	D 6874	#14 x 1-1/2" TEK w/Neo Washer	2

# Center High Mount Stop Lamp (CHMSL)



Model # SP-9500

- With spreader mounted on vehicle, plug vehicle (CHMSL) harness into spreader stop lamp harness.
- Using supplied harness clamps and screws, route harness along side wall lower corner or so that harness will be out of the way when spreader is in use.
- Locate vehicle ground wire and stop lamp power wire at rear of vehicle. Use supplied wire taps to connect harness to vehicle electrical system. Once wire taps are installed check to make sure stop lamp works when brake pedal is pressed. Properly complete installation by tying up any loose wires with ty-wraps, also add electrical tape over both connections to insure a solid electrical connection. Some newer trucks have auxiliary stop lamp power leads already at the rear for these types of applications.

## CHMSL Spreader Harness (installed on Spreader from factory)

Key	Part No.	Description	Qty.
<b>1</b>	D 6158	#10 Lock Nut	2
<b>2</b>	D 6514	CHMSL Spreader Harness	1
<b>3</b>	D 6529	#10 Black Oxide Screw	2

CONNECT TO SPREADER LIGHT  
HARNES 2-CONDUCTOR PLUG

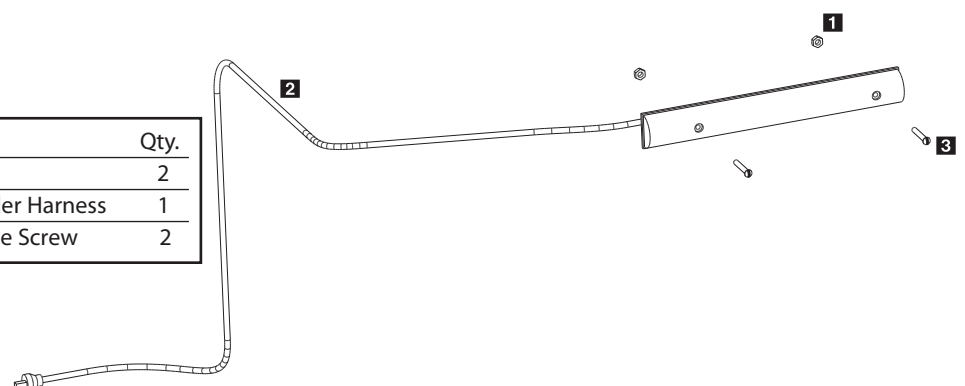

# Troubleshooting

## Model # SP-9500

Whenever service is necessary, your local SnowEx Dealer knows your Spreader best. Take your Spreader to your local dealer for any maintenance or service needs on your unit. If this is not possible, the Troubleshooting Guide below may assist you in identifying the problem **Warning:** First read all warning instructions and safety messages before servicing your spreader.

### Preliminary Checks

- Be sure all electrical connections are tight and clean.
- Be sure nothing is jammed in the hopper.

PROBLEM	POSSIBLE CAUSE	SOLUTION
Motor doesn't run.	Loose electrical connections.	Check all connections.
	Blown Fuse.	Replace fuse.
	Motor Seized.	Replace motor.
Controller shut down.	Jammed auger.	Carefully clear jammed material.
	Poor electrical connections.	Clean or replace connectors. Use dielectric grease.
	Electrical short.	Check electrical connections. Check for bare wires.
	Controller failure.	Replace controller.
Material not flowing from hopper.	Empty hopper.	Fill hopper.
	Wet material.	Replace with dry material.
	Frozen or coarse material.	Replace material.
	Spinner not turning.	Check drive assembly.
	Auger loose on shaft.	Tighten locking bolt on the side of the auger. There is a flat machined on the driver shaft. Align the auger with this flat and tighten the bolt.
	Vibrator not working.	Replace vibrator
Audible alarm beeping and display shows OL or OH.	Jammed auger, overload shut down.	Turn off for three seconds, then restart. If shut down continues, turn off controller. Clear debris and lumps from auger areas.
Audible alarm beeping display shows E1.	Short in system.	Turn off. Do not use until problem is corrected.
Audible alarm beeping display shows EO.	Motor is not getting power.	Turn off. Check all connections.
Audible alarm beeping display shows LB.	Vehicle battery is extremely low, or a poor connection exists.	Turn off. Charge battery.

# Troubleshooting

Model # SP-9500

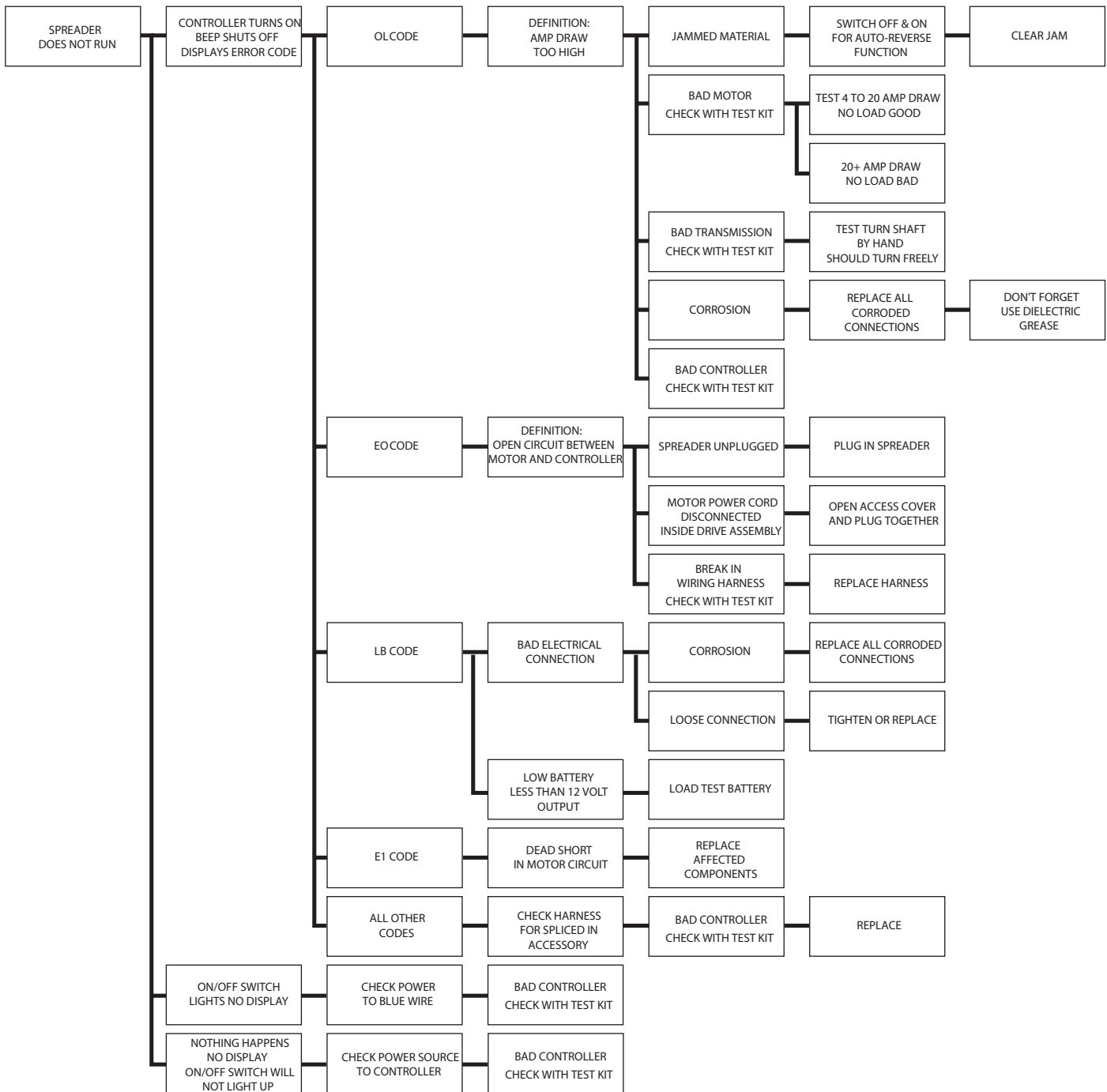

# Troubleshooting Material Flow



Model # SP-9500

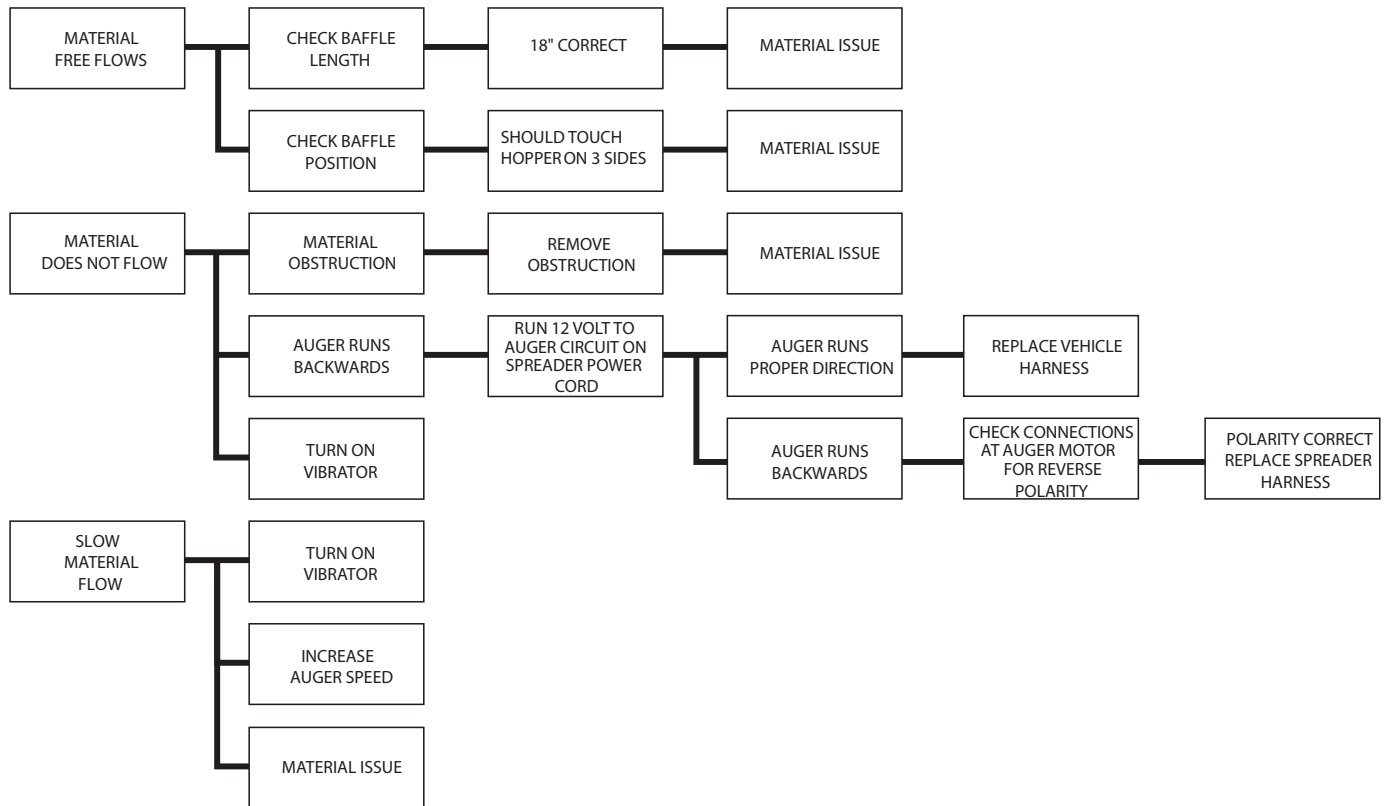

\* Spreader capable of spreading most granular bulk material.

# Spreader Maintenance

## Model # SP-9500

---

- **WARNING** – When servicing is necessary, perform it in a protected area. Do not use power tools in rain or snow because of danger of electrical shock or injury. Keep area well lighted. Use proper tools. Keep the area of service clean to help avoid accidents.
- **WARNING** – Disconnect electricity to spreader before servicing.
- **CAUTION** – The controller is a solid state electronic unit and is not serviceable. Any attempt to service will void warranty.
- **CAUTION** – There are no serviceable parts in the motor/transmission assembly. Any attempt to service will void warranty.
- **CAUTION** – When replacing parts use only original manufacturer's parts. Failure to do so will void warranty.
- Use dielectric grease on all electrical connections to prevent corrosion at the beginning and end of the season and each time plugs are disconnected.
- Gently wash unit after each use to prevent material build-up and corrosion.
- **CAUTION** – When pressure washing motor enclosure area, stay at least 36" away from all electrical items.
- Paint or oil all bare metal surfaces at the end of the season.
- Apply small amount of light oil to latches as needed.
- If motor cover is removed for any reason, use silicone sealant to ensure weather proofing of enclosure.
- Grease bearings after every 20 hour's use.
- After first use, tighten all nuts and bolts on spreader and mount.
- **WARNING:** Never remove spreader with material in hopper.
- **ATTENTION:** Store control in cool dry place during the off season.
- **CAUTION** – Spinner motor is not designed for continuous duty. Allow motor to cool between long cycle times.
- **CAUTION** – Vibrator is not designed for continuous duty. Allow motor to cool between long cycle times.
- **CAUTION** – Do not modify vehicle or spreader wiring harness. Doing so will void product warranty.

# Useful Formulas



Model # SP-9500

## Determining Vehicle Payload

Material Type	Example: Coarse Salt – Dry				
Equipment installed when vehicle was weighed	9500				
Front Gross Axle Weight Rating (RGAWR)					
Rear Vehicle Weight Rating (GVWR) (lb.)	8600				
Gross Vehicle Weight (GVW) (lb.) (empty)	– 6500	–	–	–	–
Payload Available (lb.)	= 2100	=	=	=	=
Material Weight (lb./cu. yd.)	÷ 1431	÷	÷	÷	÷
Maximum Volume (cu. yd.)	= 1.47	=	=	=	=
Maximum Height (approximate) (in.)	24"				
Loaded Front Gross Axle Weight (FGAW) (lb.)					
Loaded Rear Gross Axle Weight (RGAW) (lb.)					
Loaded Gross Vehicle Weight (GVW) (lb.)					

## Torque Chart

When tightening fasteners, refer to the Torque Chart below for the recommended fastener torque values.

Recommended Fastener Torque Chart (ft.-lb.)			
SIZE	SAE Grade 2	SAE Grade 5	SAE Grade 8
1/4-20	6	9	13
5/16-18	11	18	28
3/8-16	19	31	46
3/8-24	24	46	68
7/16-14	30	50	75
1/2-13	45	75	115
9/16-12	66	110	165
5/8-11	93	150	225
3/4-10	150	250	370
7/8-9	202	378	591
1-8	300	583	893

Metric Grade 8.8 (ft.-lb.)			
SIZE	TORQUE	SIZE	TORQUE
M 6	7	M 12	60
M 8	17	M 14	95
M 10	35	M 16	155

These torque values apply to mount assembly fasteners except those noted in the instruction.

## Material Weights

Refer to the table below for the weight per cubic yard of common spreading materials.

MATERIAL	WEIGHT (lb. per cubic yard)
Fine Salt – Dry	2,025
Coarse Salt – Dry	1,431
Sand/Salt Mix – Dry (50/50)	2,700
Cinders	1,080

**THIS PAGE INTENTIONALLY LEFT BLANK**



## Limited Warranty

Snowex products are warranted for a period of two years from the date of purchase against defects in material or workmanship under normal use and service, subject to limitations detailed below. Warranty period of two years begins on the date of purchase by the original retail user.

The WARRANTY REGISTRATION CARD must be returned to the manufacturer for this warranty to become effective. This warranty applies to the original retail purchaser only. This warranty does not cover damages caused by improper installation, misuse, lack of proper maintenance, alterations or repairs made by anyone other than authorized Snowex dealers or Snowex personnel. Due to the corrosive properties of the materials dispensed by spreaders, Trynex does not warrant against damage caused by corrosion. Warranty claims by the user must be made to the dealer from where the product was purchased, unless otherwise authorized by Snowex. Snowex reserves the right to determine if any part is defective and to repair or replace such parts as it elects. This warranty does not cover shipping costs of defective parts to or from the dealer.

### LIMITATION OF LIABILITY

Neither Snowex, nor any company affiliated with it, makes any warranties, representations for promise as to the performance or quality other than what is herein contained. The liability of Snowex to the purchaser for damages arising out of the manufacture, sale, delivery, use or resale of this spreader shall be limited to and shall not exceed the costs of repair or replacement of defective parts. Snowex shall not be liable for loss of use, inconvenience or any other incidental, indirect or consequential damages, so the above limitations on incidental or consequential damages may not apply to you.

**NO DEALER HAS AUTHORITY TO MAKE ANY REPRESENTATION OR PROMISE ON BEHALF OF SNOWEX, OR TO ALTER OR MODIFY THE TERMS OR LIMITATIONS OF THIS WARRANTY IN ANY WAY.**

# Warranty Registration and Customer Survey



To initiate the warranty on your new SnowEx spreader and assure prompt warranty service, please complete the following warranty registration and customer survey, sign and mail it back to the factory within 30 days of purchase.

- 1) Date of Purchase: \_\_\_\_\_
- 2) Name: \_\_\_\_\_  
Address: \_\_\_\_\_  
\_\_\_\_\_  
Phone: \_\_\_\_\_
- 3) SnowEx Model Purchased: \_\_\_\_\_ Serial Number: \_\_\_\_\_
- 4) Is this your first Trynex Spreader?     Yes     No
- 5) What type of vehicle are you using with your Spreader?  
Make \_\_\_\_\_ Model \_\_\_\_\_ Year \_\_\_\_\_
- 6) What type of material are you using in your spreader? \_\_\_\_\_
- 7) SnowEx Dealer Name: \_\_\_\_\_  
SnowEx Dealer Address: \_\_\_\_\_  
\_\_\_\_\_  
SnowEx Dealer Phone: \_\_\_\_\_
- 8) Does your Trynex Dealer stock Trynex replacement Parts?     Yes     No     I don't know
- 9) Do you feel your Trynex Dealer sold you the correct product for your needs/application?     Yes     No
- 10) How would you rate your overall satisfaction with your SnowEx Dealer?  

<input type="checkbox"/>	<input type="checkbox"/>	<input type="checkbox"/>	<input type="checkbox"/>	<input type="checkbox"/>	<input type="checkbox"/>	<input type="checkbox"/>
Very Satisfied	Satisfied	Somewhat Satisfied	Somewhat Dissatisfied	Dissatisfied	Very Dissatisfied	
- 11) How would you rate your overall satisfaction with your SnowEx Product?  

<input type="checkbox"/>	<input type="checkbox"/>	<input type="checkbox"/>	<input type="checkbox"/>	<input type="checkbox"/>	<input type="checkbox"/>	<input type="checkbox"/>
Very Satisfied	Satisfied	Somewhat Satisfied	Somewhat Dissatisfied	Dissatisfied	Very Dissatisfied	
- 12) Would you purchase another Trynex Product?     Yes     No
- 13) If you would like to receive **E-Mail ALERTS** for new products, bulletins or special promotions please supply address: \_\_\_\_\_
- 14) Please use the space below to convey your comments and/or suggestions.  
\_\_\_\_\_  
\_\_\_\_\_  
\_\_\_\_\_  
\_\_\_\_\_
- NOTE: I have read the owner's manual and all safety precautions and I understand that this equipment could be dangerous if not operated with care and under the proper conditions.
- 15) Owner's signature:    **X** \_\_\_\_\_

PLEASE FOLD AND SEAL WITH TRANSPARENT TAPE BEFORE MAILING.

Warm Up to

**SNOWEX** 

with a

**FREE**

**Winter Band!**



Simply Fill Out Your  
Warranty Registration and  
Return It to the Factory!

From:

\_\_\_\_\_  
\_\_\_\_\_  
\_\_\_\_\_



Postage  
Required  
Post Office will  
not deliver  
without proper  
postage.

**TRYNEX**   
INTERNATIONAL

23455 REGENCY PARK DR.  
WARREN MI 48089-2667

